



PTS 1



GTS 1



Falling down protection



Push trolley | **PTS**



Gear type trolley | **GTS**

## TROLLEY | **PTS & GTS**

The trolleys are manufactured in high quality and are designed for hard and durable operation. The PREMIUM PRO and PULLMASTER-II manual chain hoists with the same load capacity can be easily hooked in and out with the hook. The trolleys have rubber buffers on both sides! Can be used in ambient temperatures from -20 °C to +60 °C.

### Wide adjustment range

By turning the threaded spindle, the trolley can be adjusted to many beam widths.

The profiled rollers are suitable for all common carrier profiles, so that this trolley can be used very flexibly.

The standard flange width can be up to 220 mm, but is reduced to 203 mm if the optional lock nuts are used to prevent rotation of the threaded spindle.

Once the trolley has been adjusted to the appropriate flange width and a hoist has been attached, the spindle can no longer rotate.

**Important: The manual trolleys shown are designed for use with manual hoists. use with manual lifting equipment.**



**Option:**  
PTS with  
manual chain  
hoist PREMIUM  
PRO



**Option:**  
GTS with  
manual chain  
hoist PREMIUM  
PRO

PTS

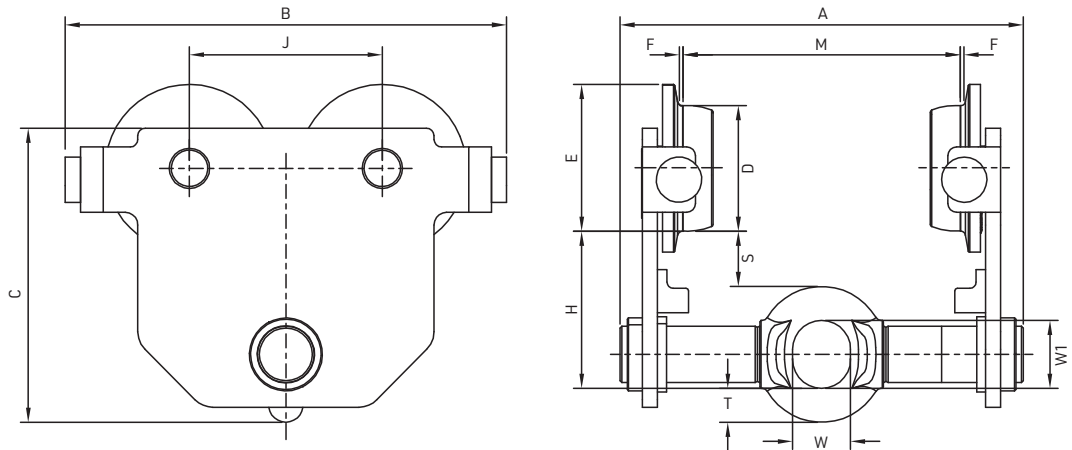

GTS

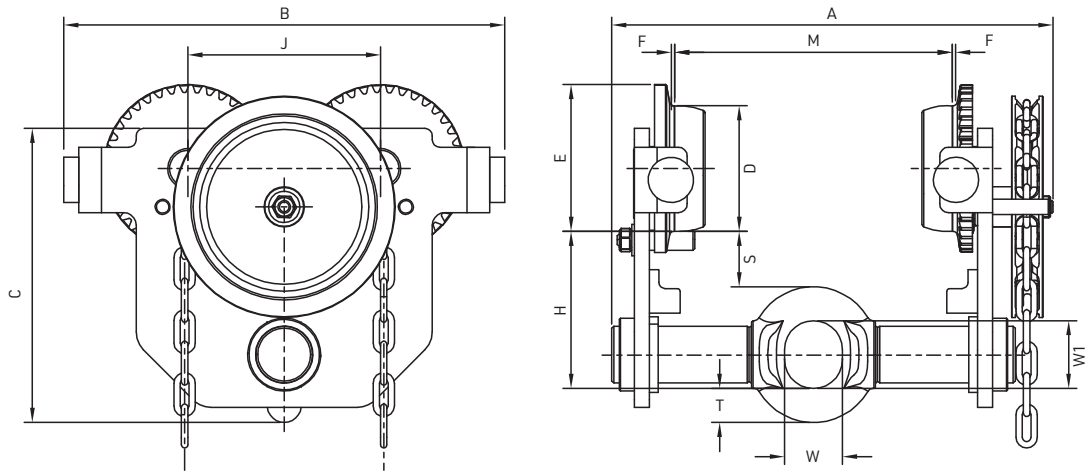

TYPE	Push trolley PTS...	0.5	1	2	3	5
TYPE	Gear type trolley GTS...	0.5	1	2	3	5
Capacity	kg	500	1,000	2,000	3,000	5,000
Flange width M min. - max.	mm	48 - 203	48 - 203	66 - 203	72 - 203	90 - 203
Min. curve radius	m	0.8	0.9	1	1.2	1.3
Hand chain operation length GTS	m	2.5	2.5	2.5	2.5	2.5
Hand chain size GTS	mm	5 × 25	5 × 25	5 × 25	5 × 25	5 × 25
Reel path for 1 m path GTS	m	3	3.6	4.7	5.7	6.3
A (Dimensions)	mm	292	300	310	320	336
A1	mm	330	336	346	350	363
B	mm	222	256	300	350	404
C	mm	133	160	193	234	260
D	mm	54	67	80	100	109
E	mm	66	82	95	117	127
H	mm	72	92	104	125	139
J	mm	102	112	131	153	168
S	mm	26	40	34	44	39
F	mm	2	2	2	3	3
W	mm	25	30	39	46	57
W1	mm	30	35	46	54	67
T	mm	16	17	24	27	33
Net weight PTS	kg	5.7	9.1	14.9	25.2	37.8
Net weight GTS	kg	8.7	12.1	18.1	28.7	41.6
PTS	Order No.	S20000	S20001	S20002	S20003	S20004
GTS with 2.5 m operation length	Order No.	S20006	S20007	S20008	S20009	S20010
Add. operator length hand chain per m	Order No.	G20017	G20017	G20017	G20017	G20017
Lock nut galvanized	Order No.	S20013	S20014	S20015	S20016	S20018

More capacities on request!