



**Industrias  
GALARZA, S.A.**®

Leaders in electrical conductivity since 1958

**CATALOGUE 2020**



**TRACK PROFILE**

**MAX. LOAD  
PER  
TROLLEY**

**DESCRIPTION**

**SERIES**

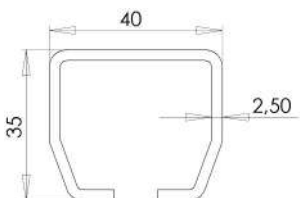

**40 KG**

**FESTOON SYSTEM  
RUNNING ON A  
C-PROFILE 40 X 35MM**

**2500**



Max cable package: 90 (L) x 30 (H) mm



# GENERAL SALES CONDITIONS, SUPPLY AND WARRANTY

## Generalities

The supply of the products contained in this catalogue is subject to the conformity of the tariff in force at the moment and the terms contained in these General Conditions of Sale and Guarantees.

## Orders and prices

All orders received by IGA will be confirmed via fax or email. If in the following 24 hours IGA does not receive any claim, they will be considered definitive. IGA reserves the right to accept or reject any order.

## Codes

The codes indicated in this catalogue are the standard products of IGA.

## Delivery time

If for reasons beyond our control we can not fulfill this service commitment, IGA will inform the customer of the new term within a maximum of 48 hours after the reception of the order.

The rest of references will be served in the shortest period of time possible and may make partial deliveries.

Orders received that have a delivery time less than 72 hours, will follow the procedure described above.

The breach of the previous commitment or a fractioned issue will not be grounds for compensation.

## Transport

Our products are considered expired in our warehouse and the date of issue is shown on the delivery note.

The goods travels at the addressee expense and risk, even if they are sent prepaid.

In the case of lack of packages or visible damages due to transportation, the addressee must write it down on the delivery note, claim the carrier and inform the commercial department of IGA within 48 hours. Otherwise, it will be considered the conformity of the goods in quantity and condition. Claims for delays in transportation will not be accepted.

After 8 days from receipt of the goods, no claims will be accepted about the contents of the boxes.

## Refunds

The products invoiced by IGA are considered a firm sale and has no right to refund.

In case of an error in the execution of the order, the following shall be taken into account:

- The change must be authorized by the commercial direction of IGA. The warehouse of IGA will not accept any product without authorization.

- The accepted material will have a 20% reduction of its value for verification expenses.

- The goods returned to IGA travel at the client's risk.

## Installations

IGA is exempted from any responsibility in the installations that do not comply with the advice or with the specifications and features of each range of product.

## Warranty

IGA range of products has a 2 year warranty. The acknowledgment of the responsibility in warranty corresponds only to IGA and / or to its insurance company. Any other defect caused by aging, corrosion, improper installation or improper application, will not be subject to possible claims.

## Jurisdiction

IGA will try to resolve any divergence with his clients through friendly channels. Having said that, in case of litigation, the parties agree and are obliged to submit to the arbitration appointed by the Court of the Arbitration Association of Bilbao, which will be responsible for the administration of the aforementioned arbitration in accordance with its Statute and Regulations. Likewise, they are obliged from now on to comply with the arbitral report that is issued.

IGA reserves the modification of the articles without previous notice.

## NOTES OF INTEREST

### KIT FESTOON:

IGA offers the possibility of supplying the entire FESTOON system assembled under the customer's specifications.



KIT FESTOON

### FINAL PLUGS FOR THE PROFILE:

The option of plastic material caps to close both ends of the rolling profile has been added to our catalogue.

NOTE: The CM brackets have these series plugs incorporated.



Twitter  
@indgalarza



Facebook  
Industrias Galarza, S.A.



LinkedIn  
Industrias Galarza, S.A.

## INDEX

Profile	Page. 03	Pendant control unit trolley	Page. 07
Joint	Page. 03	Serie 2503	Page. 08
Hanger	Page. 03	TROLLEYS FOR ROUND CABLE	
FLAT CABLE PROFILE		Serie 2504	Page. 09-10
Serie 2500	Page. 04	Assembly set	Page. 11
Serie 2500-100	Page. 05	Accesories	Page. 12
Serie 2500-150	Page. 06	Assembly instructions	Page. 13-14



# FESTOON SYSTEM SERIES 2500

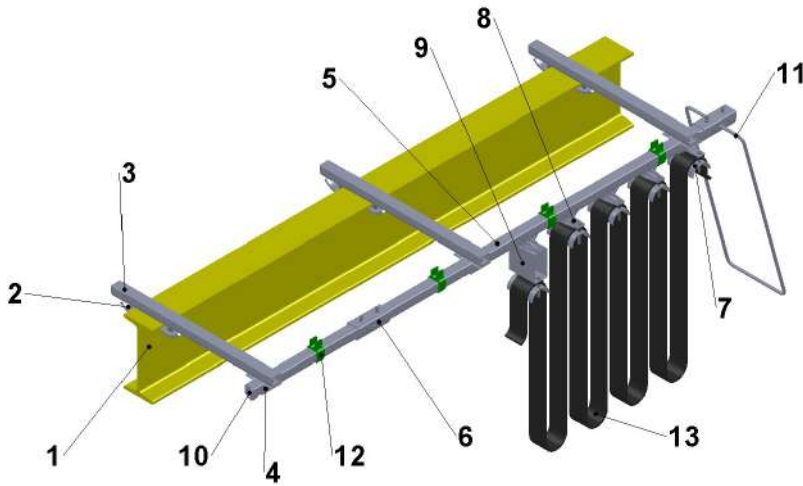

1. Beam
2. Beam clip
3. Cross arm support
4. Track hanger
5. Track profile
6. Track joint
7. End clamp
8. Cable trolley
9. Towing trolley
10. End bumper stop
11. Protection
12. Cable clamp
13. Cable

MAXIMUM CABLE PACKAGE: 90 (L) X 30 (H) MM

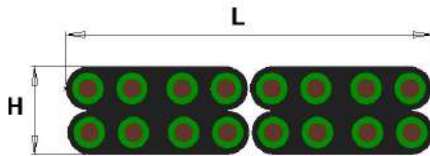

In aggressive indoor / outdoor conditions the metal parts (bodies and cable holders) are supplied with EPOXY paint or made in stainless steel AISI 304

TEMPERATUR RANGE: -15°C / +80°C.

MAX. LOAD CAPACITY PER TROLLEY: 40 KG

## NUMBER OF TROLLEYS REQUIRED:

$$N = (L / 2xH) - 1$$

Where:  
 N: number of cable trolleys  
 L: travelling length  
 H: maximum loop height

## REQUIRED AMBUSH LENGTH

$$b = (N + 1) \times m$$

Where:  
 b: maximum ambush length  
 N: number of cable trolleys  
 m: trolley length

## PROFILE

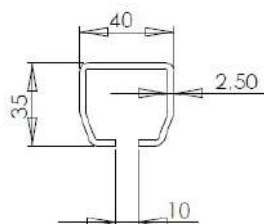

REFERENCIE	CODE	MATERIAL	LENGHT	WEIGHT
2500-1	305001	Galvanised Steel	5 Meters	2,2 Kg/m
2500-1-Inox	305342	Stainless steel AISI 316	5 Meters	2,2 Kg/m

- Section: 3,022 cm<sup>2</sup>
- Ix: 4,985 cm<sup>4</sup>
- Wx: 2,611 cm<sup>3</sup>



# FESTOON SYSTEM SERIES 2500

## TRACK JOINT

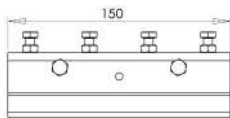

REFERENCE	CODE	MATERIAL		WEIGHT
		Body	Screws	
2500-3	305003	Zinc plated steel	Zinc plated steel	0,510 Kg
2500-3-PLY	305011	Painted steel	Stainless steel	0,520 Kg
2500-3-Inox	305423	Stainless steel	Stainless steel	0,510 Kg

## TRACK HANGER BRACKET

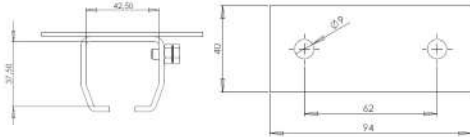

REFERENCE	CODE	MATERIAL		WEIGHT
		Body	Screws	
2500-4	305004	Zinc plated Steel	Zinc plated steel	0,242 Kg
2500-4-PLY	305012	Painted steel	Stainless steel	0,252 Kg
2500-4-Inox	305424	Stainless steel	Stainless steel	0,242 Kg

## CEILING TRACK HANGER BRACKET

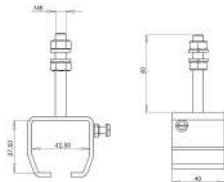

REFERENCE	CODE	MATERIAL		WEIGHT
		Body	Screws	
2500-4-R	305338	Zinc plated steel	Zinc plated steel	0,242 Kg
2500-4-R-Inox	305426	Stainless steel	Stainless steel	0,242 Kg

## LATERAL TRACK HANGER BRACKET

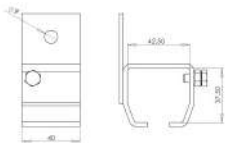

REFERENCE	CODE	MATERIAL		WEIGHT
		Body	Screws	
2500-4-L	305172	Zinc plated steel	Zinc plated steel	0,245 Kg
2500-4-L Inox	305464	Stainless steel	Stainless steel	0,245 Kg

## SERIES 2500

Maximum flat cable package: 90x30mm  
Round cables up to Ø12mm

## END CLAMP

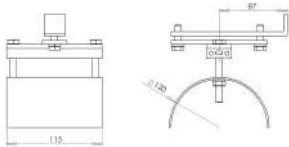

REFERENCE	CODE	MATERIAL		WEIGHT
		Body + Saddle	Screws	
2500-2	305002	Zinc plated steel	Zinc plated steel	0,900 Kg
2500-2-PLY	305010	Painted steel	Stainless steel	0,910 Kg
2500-2-Inox	305428	Stainless steel	Stainless steel	0,900 Kg

## CABLE TROLLEY

Saddle ø120mm

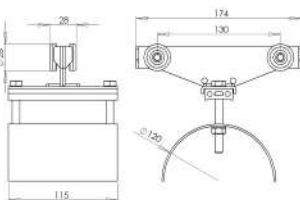

REFERENCE	CODE	MATERIAL		WEIGHT
		Body + Saddle	Screws+ wheels	
2500-5	305005	Zinc plated steel	Zinc plated steel	0,860 Kg
2500-5-PLY	305013	Painted steel	Stainless steel	0,870 Kg
2500-5-Inox	305431	Stainless steel	Stainless steel	0,860 Kg

## TOWING TROLLEY

Saddle ø120mm

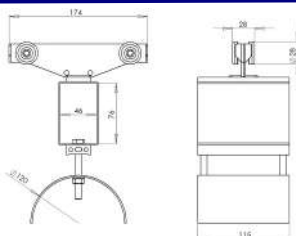

REFERENCE	CODE	MATERIAL		WEIGHT
		Body + Saddle + Towing Attachment	Screws+ wheels	
2500-6	305006	Zinc plated steel	Zinc plated steel	1,450 Kg
2500-6-PLY	305014	Painted steel	Stainless steel	1,460 Kg
2500-6-Inox	305434	Stainless steel	Stainless steel	1,450 Kg



# SERIES 2500-100

Maximum flat cable package: 58x20mm  
Round cables up to Ø6mm

## END CLAMP

Saddle ø55mm

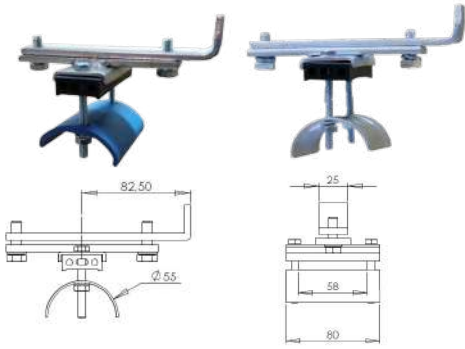

REFERENCE	CODE	MATERIAL			WEIGHT
		Body	Saddle	Screws	
2500-100-2	305021	Zinc plated steel	Polypropylene	Zinc platt. steel	0,365 Kg
2500-100-C-2	305131	Zinc plated steel	Zinc platt. steel	Zinc platt. steel	0,460 Kg
2500-100-2-PLY	305026	Painted steel	Polypropylene	Stainless steel	0,375 Kg
2500-100-C-2-PLY	305197	Painted steel	Painted steel	Stainless steel	0,470 Kg
2500-100-2-Inox	305449	Stainless steel	Polypropylene	Stainless steel	0,365 Kg
2500-100-CH-2-Inox	305429	Stainless steel	Stainless steel	Stainless steel	0,460 Kg

## CABLE TROLLEY

Saddle ø55mm

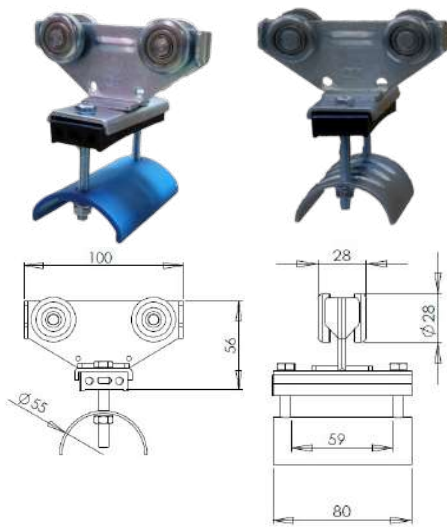

REFERENCE	CODE	MATERIAL			WEIGHT
		Body	Saddle	Screws+ Wheels	
2500-100-5	305024	Zinc patted steel	Polypropylene	Zinc plated steel	0,415 Kg
2500-100-C-5	305128	Zinc plated steel	Zinc plated steel	Zinc plated steel	0,510 Kg
2500-100-5-PLY	305029	Painted steel	Polypropylene	Stainless steel	0,425 Kg
2500-100-C-5-PLY	305198	Painted steel	Painted steel	Stainless steel	0,520 Kg
2500-100-5-Inox	305450	Stainless steel	Polypropylene	Stainless steel	0,415 Kg
2500-100-CH-5-Inox	305432	Stainless steel	Stainless steel	Stainless steel	0,510 Kg

# SERIES 2500-150

Maximum flat cable package: 65x25mm  
Round cables up to Ø10mm

## END CLAMP

Saddle ø100mm

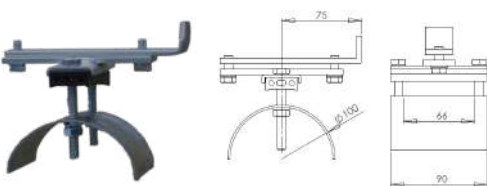

REFERENCE	CODE	MATERIAL			WEIGHT
		Body	Saddle	Screws	
2500-150-2	305032	Zinc plated steel	Zinc plated steel	Zinc plated steel	0,715 Kg
2500-150-2-PLY	305037	Painted steel	Painted steel	Stainless steel	0,725 Kg
2500-150-2-Inox	305430	Stainless steel	Stainless steel	Stainless steel	0,715 Kg

## CABLE TROLLEY

Saddle ø100mm

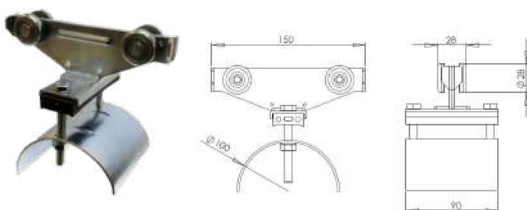

REFERENCE	CODE	MATERIAL			WEIGHT
		Body	Saddle	Screws+ Wheels	
2500-150-5	305035	Zinc plated steel	Zinc plated steel	Zinc plated steel	0,700 Kg
2500-150-5-PLY	305040	Painted steel	Painted steel	Stainless steel	0,710 Kg
2500-150-5-Inox	305433	Stainless steel	Stainless steel	Stainless steel	0,700 Kg



# FESTOON SYSTEM SERIES 2500

## PENDANT CONTROL UNIT TROLLEY

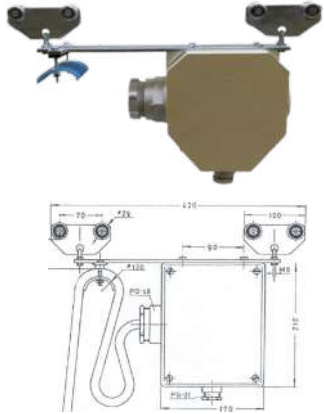

REFERENCE	CODE	MATERIAL					WEIGHT
		Ball bearing + Screws	Body	Saddle	Junction box	Cable Gland	
2500-7	305007	Zinc plated steel	Zinc plated steel	Zinc plated steel	Polyester + Glass fiber	Polyamide	3,200 Kg
2500-7-PLY	305015	Stainless steel	Painted steel	Painted steel	Polyester + Glass fiber	Polyamide	3,210 Kg
2500-7-Inox	305451	Stainless steel	Stainless steel	Stainless steel	Polyester + Glass fiber	Polyamide	3,200 Kg

## QUICK DISCONNECT PENDANT CONTROL UNIT TROLLEY

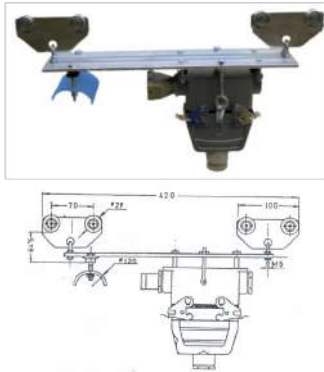

REFERENCE	CODE	MATERIAL					WEIGHT
		Body	Screws+ Wheels	Saddle	Multipole Conector	Cable Gland	
2500-7-C16	305152	Zinc plated Steel	Zinc plated Steel	Zinc plated steel	Formed aluminium	Polyethylene	3,200 Kg
2500-7-C24	305153	Zinc plated Steel	Zinc plated Steel	Zinc Ppated steel	Formed aluminium	Polyethylene	3,531 Kg
2500-7-C16-PLY	305452	Painted steel	Stainless steel	Painted steel	Formed aluminium	Polyethylene	3,210 Kg
2500-7-C24-PLY	305453	Painted steel	Stainless steel	Painted steel	Formed aluminium	Polyethylene	3,531 Kg
2500-7-C16-Inox	305454	Stainless steel	Stainless steel	Stainless steel	Formed aluminium	Polyethylene	3,200 Kg
2500-7-C24-Inox	305455	Stainless steel	Stainless steel	Stainless steel	Formed auminium	Polyethylene	3,531 Kg

REF. 2500-7-C16  
(16 poles)

REF. 2500-7-C24  
(24 poles)

## SERIES 2503-L-PL

The dimensions (trolley lenght, saddle diameter and saddle width) can be modified to adapt to customers needs.

### END CLAMP

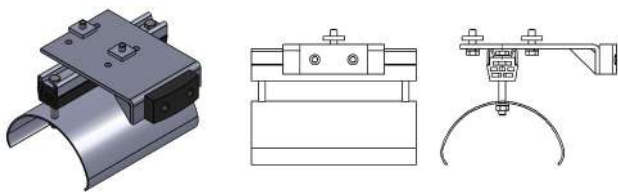

REFERENCE	CODE	MATERIAL	
		Body + Saddle	Screws
2503-L-PL-2	--	Zinc plated steel	Zinc plated steel
2503-L-PL-2-PLY	--	EPOXY painted steel	Stainless steel
2503-L-PL-2-Inox	--	Stainless steel	Stainless steel

### CABLE TROLLEY

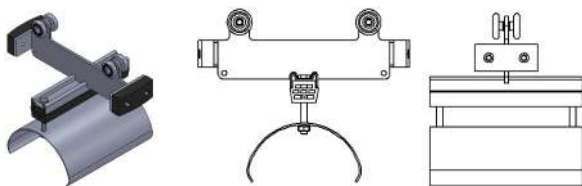

REFERENCE	CODE	MATERIAL	
		Body + Saddle	Screws + Wheels
2503-L-PL-5	--	Zinc plated steel	Zinc plated steel
2503-L-PL-5-PLY	--	Painted steel	Stainless steel
2503-L-PL-5-Inox	--	Stainless steel	Stainless Ssteel

### TOWING TROLLEY

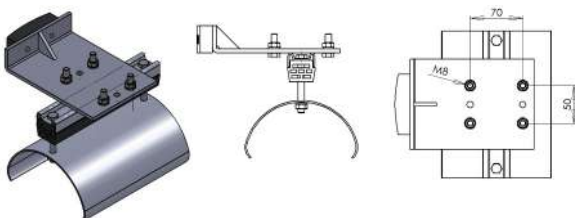

REFERENCE	CODE	MATERIAL	
		Body + Saddle	Screws + Wheels
2503-L-PL-6	--	Zinc plated steel	Zinc plated steel
2503-L-PL-6-PLY	--	Painted steel	Stainless steel
2503-L-PL-6-Inox	--	Stainless steel	Stainless steel



# SERIES 2504 ROUND CABLES



## END CLAMP

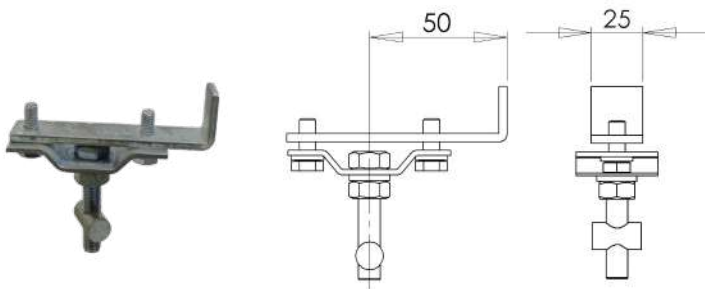

REFERENCE	CODE	MATERIAL	MAX. LOAD	WEIGHT
2504-2	305207	Zinc plated steel	40 Kg	0,132 Kg
2504-2-Inox	305456	Stainless steel	40 Kg	0,132 Kg

## CABLE TROLLEY

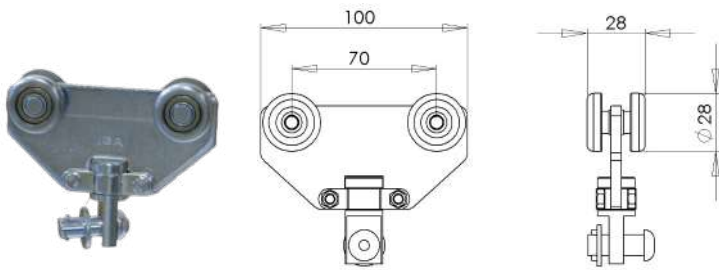

REFERENCE	CODE	MATERIAL	MAX. LOAD	WEIGHT
2504-5	305125	Zinc plated steel	40 Kg	0,408 Kg
2504-5-Inox	305457	Stainless steel	40 Kg	0,408 Kg

## TOWING TROLLEY

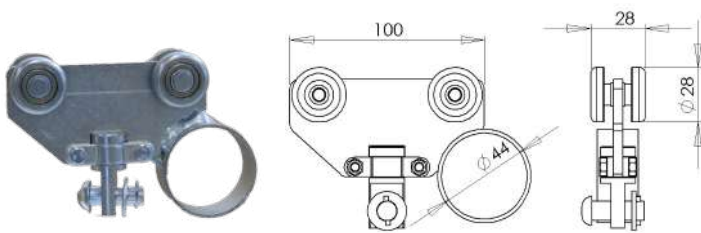

REFERENCE	CODE	MATERIAL	MAX. LOAD	WEIGHT
2504-6	305173	Zinc plated steel	40 Kg	0,470 Kg
2504-6-Inox	305458	Stainless steel	40 Kg	0,470 Kg

## CLIP "+A" for cables from $\varnothing$ 8mm to $\varnothing$ 15mm



REFERENCE	CODE	MATERIAL	SCREWS	WEIGHT
+A	303251	Aluminium	Zinc plated steel	0,104 Kg
+A-Inox	303596	Aluminium	Stainless steel	0,104 Kg

## CLIP "+B" for cables from $\varnothing$ 16mm to $\varnothing$ 24mm



REFERENCE	CODE	MATERIAL	SCREWS	WEIGHT
+B	303252	Aluminium	Zinc plated steel	0,114 Kg
+B-Inox	303597	Aluminium	Stainless steel	0,114 Kg

## CLIP "+C" for cables from $\varnothing$ 25mm to $\varnothing$ 35mm

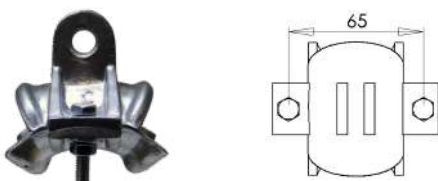

REFERENCE	CODE	MATERIAL	SCREWS	WEIGHT
+C	303253	Aluminium	Zinc plated steel	0,150 Kg
+C-Inox	303598	Aluminium	Stainless steel	0,150 Kg



# SERIES 2504 ROUND CABLES



## “T” UNION

REFERENCE	CODE	MATERIAL	SCREWS + RIVETS	WEIGHT
T	303496	Stainless steel	Zinc Plated steel	0,107 Kg
T-Inox	303599	Stainless steel	Stainless steel	0,107 Kg

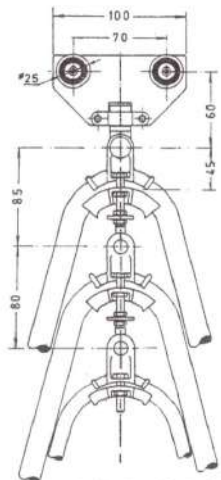
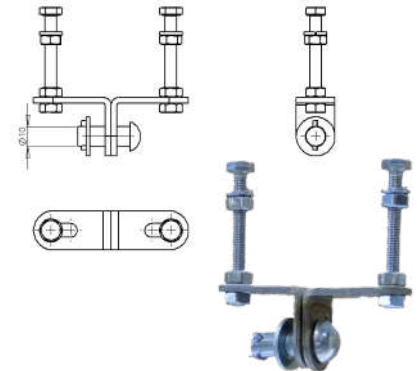

Intermedio - Ref. 2.335 + C + B + A-5

The clip makes a 90 degree turn in order to make easier the parking. When ordering, add to the reference, the necessary clips, followed by the indicative number: end clamp (-2), cable trolley (-5) or towing trolley (-6).

Example:

- End clamp ref. 2504+C+B-2.
- Cable trolley ref. 2504+B+B+A-5.
- Towing trolley ref. 2504+A-6.

## SERIES 2500 CARRYING TROLLEYS

### SINGLE AXLE CARRYING TROLLEY

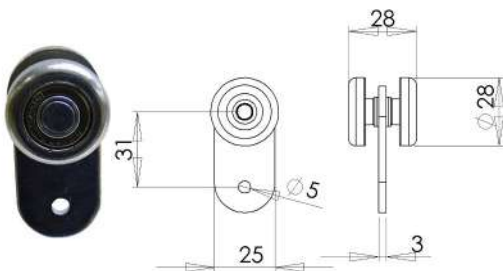

REFERENCE	CODE	MATERIAL	MAX. LOAD	WEIGHT
2330-28	305154	Zinc plated steel	20 Kg	0,060 Kg
2330-28-Inox	305435	Stainless steel	20 Kg	0,060 Kg

### DOUBLE AXLE CARRYING TROLLEY

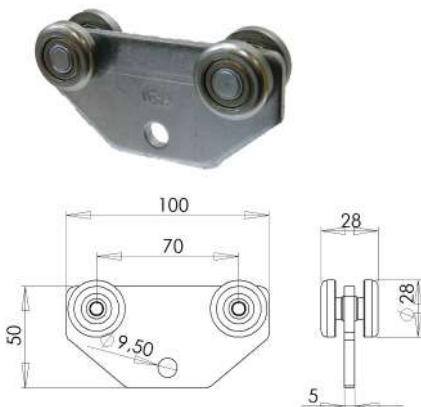

REFERENCE	CODE	MATERIAL	MAX. LOAD	WEIGHT
2330-D-28	305126	Zinc plated steel	40 Kg	0,215 Kg
2330-D-28-Inox	305436	Stainless steel	40 Kg	0,215 Kg





# STANDARD BRACKET FOR SERIES 2500

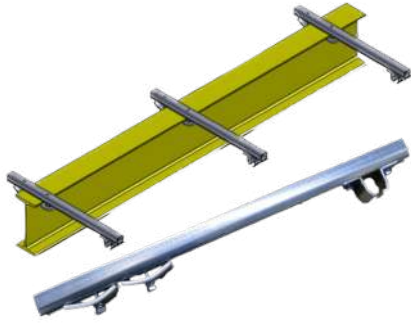

REFERENCE	CODE	MATERIAL			WEIGHT
		Anchoring device	Beam clip	Track support	
CM-5	—	Zinc plated steel	Zinc plated steel	Galvanised steel	—
CM-5-inox	—	Stainless Steel	Stainless steel	Stainless steel	—

Point out the total length (L) of it.  
Example:  
- CM-5-500.

Braço composto por:  
- 1 Cross support arm 2500-1 (L)  
- 2 Beam claws 2340-12-500  
- 1 Track holder 2500-4A-500

## TRACK HOLDER

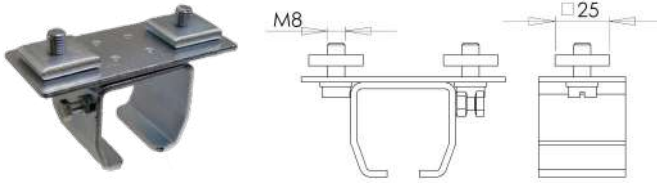

FOR ARM	REFERENCE	CODE	MATERIAL	WEIGHT
2500-1	2500-4A-500	305155	Zinc plated steel	0,260 Kg
2500-1-Inox	2500-4A-500-Inox	305425	Stainless steel	0,260 Kg

## BEAM CLIP

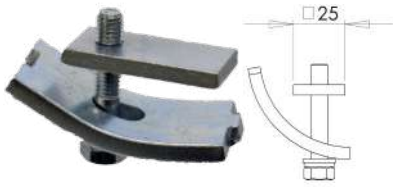

REFERENCE	CODE	MATERIAL		WEIGHT	
		Body	Screws		
For profile 2500-1	2340-12-500	309006	Zinc plated steel	Zinc Plated steel	0,156 Kg
For profile 2500-1-Inox	2340-12-500-Inox	309316	Stainless steel	Stainless steel	0,156 Kg

## WELD-ON BRACKET FOR SUPPORT ARM

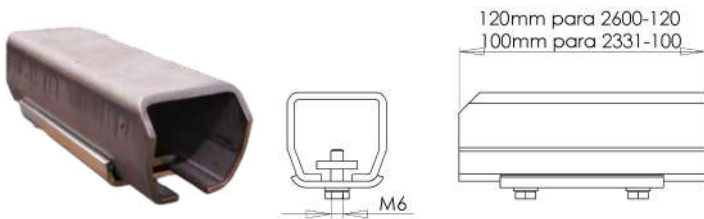

FOR ARM	REFERENCE	CODE	MATERIAL	WEIGHT
2500-1	2600-120	310011	Steel	0,600 Kg

## END BUMPER STOP



REFERENCE	CODE	MATERIAL	WEIGHT
2502-2	305018	Zinc plated steel	0,175 Kg
2502-2-Inox	305427	Stainless steel	0,175 Kg

## CLAMP B

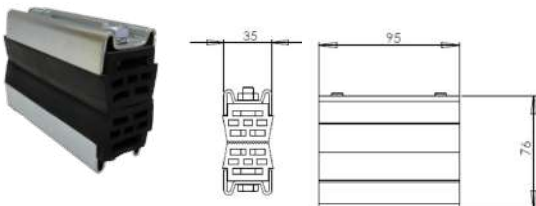

REFERENCE	CODE	MATERIAL	WEIGHT
B-58	302009	Zinc plated St+ rubber	0,455 Kg
B-90	304010	Galvanised St. + rubber	0,593 Kg
B-58-Inox	302473	Stainless St+ rubber	0,455 Kg
B-90-Inox	317004	Stainless St+ rubber	0,593 Kg

## END CAPS



FOR PROFILE	REFERENCE	CODE	MATERIAL	WEIGHT
2500-1	2500-EC	305474	Black polyethylene	0,006 Kg



# ASSEMBLY INSTRUCTIONS

## 1) SECURITY

### 1.1 Advices about electricity

- Disconnect the power from the system before starting any assembly operation.
- Do not use electrical cables for higher loads than the specified voltage and current.

### 1.2 Operational advices

- Do not use different cables for which the festoon system is specified. Any change in number, diameter, weight, etc., may affect the normal operation of the cable system.

### 1.3 Maintenance advice

- The modification of the number and/or characteristics of the festoon system components cancels the warranty.

## 2) INSTALACIÓN

-The support structure for the festoon system must be capable of supporting the total weight of the festoon system. Place the support along the beam through which the hoist is to be circulated. These points must be located every 2m, except in the parking area where they must be located every 1m.



**STANDARD BRACKETS**



**BEAM WELDED JOINT BAR**



**BEAM WELDED SUPPORT**



Install the first profile in the supports 2500-4 without tightening the screws.



Assemble the next profile section on its corresponding 2500-4 supports in the same way as the first.



Join these profiles using the joints 2500-3 that guarantee a continuous travel between both sections. Tighten the screws once the joint has been placed in the middle of both profile sections. Repeat the same operation for the rest of the profile sections.



Once all the profiles have been assembled, we will proceed to align the path with respect to the rolling hoist on the beam, crane, etc. Once the alignment is correct, we will proceed to tighten the screws of the supports 2500-4.



# ASSEMBLY INSTRUCTIONS



Cut the necessary length of electrical cable leaving enough length on both sides to make the electrical connections later. Make marks with white chalk on the cable in the required points, according to the height of the loop or number of trolleys to be assembled. Put the cables in the saddle (biggest cables should be mounted on top of the cable package).

Tighten the screws of the cable holders avoiding damaging the cables due to excessive tightening. The cable package should be as centered as possible on the cable holder, so that the trolley runs in a balanced way. Make sure that the smallest cables do not slip into the cable package.



Insert the festoon system into the profile, starting first with the towing trolley and then following the cable trolleys. Insert the end clamp the last. The cables must be mounted without any rotation.

Tighten the end clamp at the end of the profile. Make the connections of the cables on both sides of the system in their respective connection boxes.

## 3 ) OPERATION

### 3.1 Previous tests

Carry out several travels by hand to check that it moves throughout its length without problems.

Check that there is plenty of space in the ambush area.

Check that the cable loops don't get hooked in any part of the travel.

In the cable management system, check the correct height between the pushbutton pendant control station and the floor.

### 3.2 Final tests

Once the electric current is connected, check that the trolleys move forward and backward without problems.

Check that the device, the festoon system is powered on, works correctly.

### 3.3 Normal functioning

Do not exceed the maximum voltage and / or amperage specified for the electric cables.

Use the festoon system within its corresponding electrical and / or mechanical specifications.

## 4 ) MAINTENANCE

Perform periodic maintenance tasks to ensure the status of the festoon system. The maintenance operations will depend on the use given to the system.

During each inspection the following points should be checked:

- Wear of ball bearings.
- Ensure screws are correctly tightened.
- Separation or alignment in the joints.
- Electric cables: cuts, cracks, etc...
- The profile must be clean in the running edges.



# Industrias GALARZA, S.A.<sup>®</sup>

Leaders in electrical conductivity since 1958

## RANGE OF PRODUCTS

Multipole enclosed conductor systems	Single pole enclosed conductor systems	Materials for unguarded conductor systems	Insulators and moulded pieces
Festoon systems	Atex	Cable glands and electric cables	Cable reels

## MARKETS

<b>CRANES</b>	<b>PORTS&amp;CONTAINERS HANDLING</b>	<b>BULK MATERIAL HANDLING</b>	<b>METALLURGY</b>
<b>MINNING &amp; ENERGY</b>	<b>TUNNELLING</b>	<b>ENVIRONMENTAL TECHNOLOGY</b>	<b>WIND POWER</b>
<b>AUTOMOTIVE</b>	<b>OFFSHORE</b>	<b>THEATRE STAGE TECH.</b>	<b>AGRICULTURE</b>

INDUSTRIAS GALARZA S.A.  
 P.I. Bidosola, Pab. D-4  
 48142 ARTEA (BIZKAIA)  
 SPAIN  
 Tel. +34 944 47 18 12  
 Fax. +34 944 76 42 76  
 E.mail: info@industriasgalarza.com  
 www.industriasgalarza.com

DISTRIBUTED BY: