

ERSATZTEILE

Pièces de rechange - Onderdelen - Reservedele - Varaosat - Pezzi di ricambio
Reservedelen - Peças - Reservdelar - Piezas de recambio

SPARE PARTS

STROMLAUFPLÄNE

Schéma de connexions - Stroomschema - Kredslobsdiagrammer - KytKentäkaavio
Aansluitschema - Schema elettrico - Koplingskjema - Esquema electrico - Elschema
Esquema eléctrico

CIRCUIT DIAGRAMS

GIS CHAIN HOIST

☞ SWISS QUALITY

GCH 1000

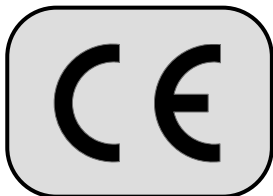

M A D E I N S W I T Z E R L A N D



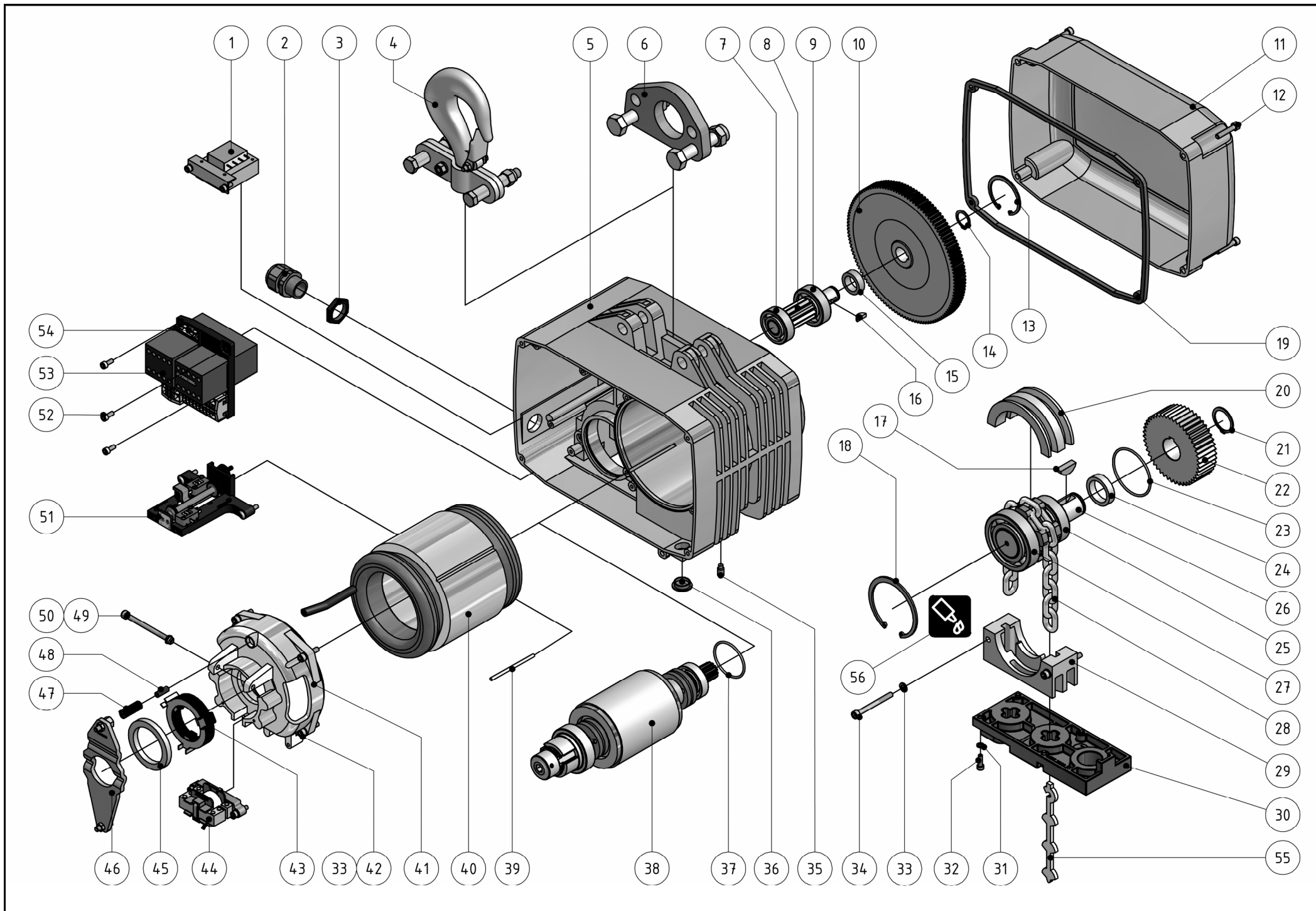

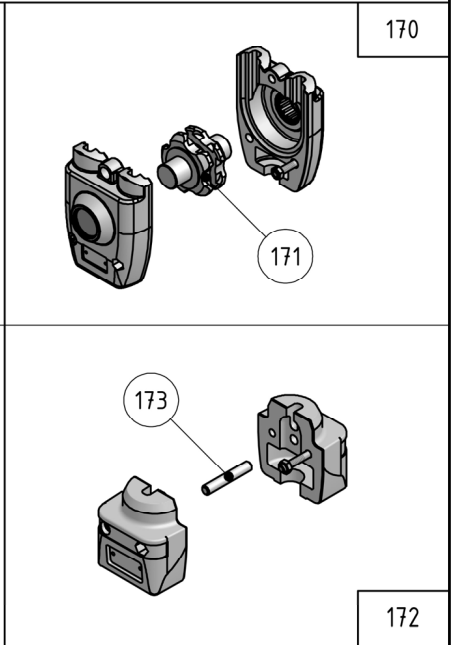
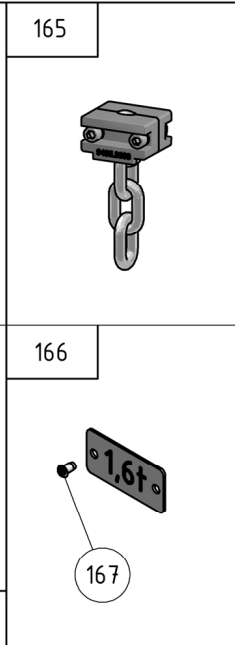
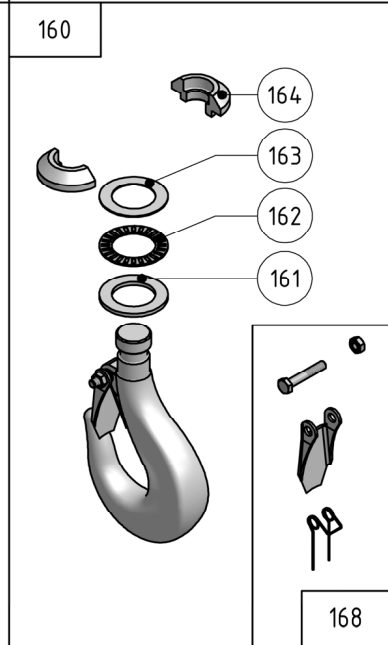
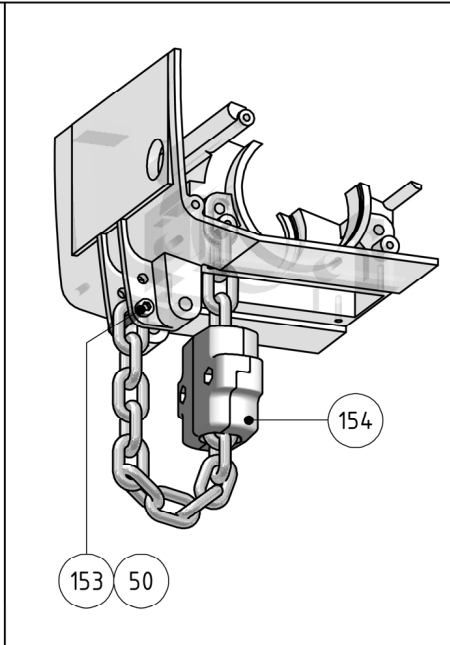
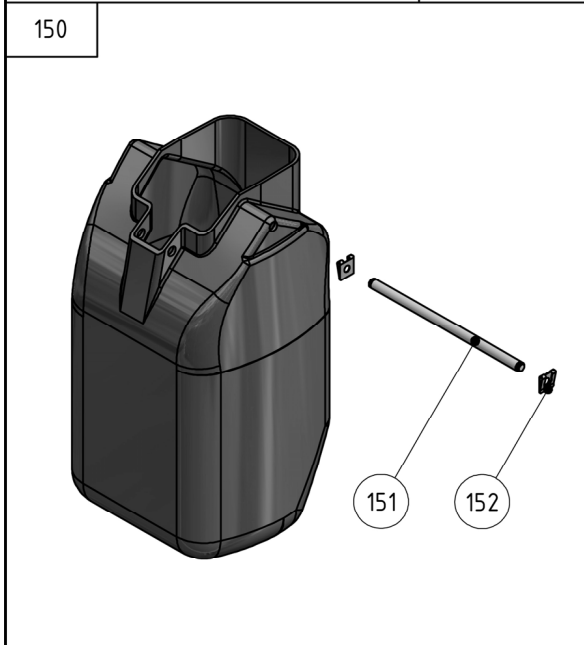
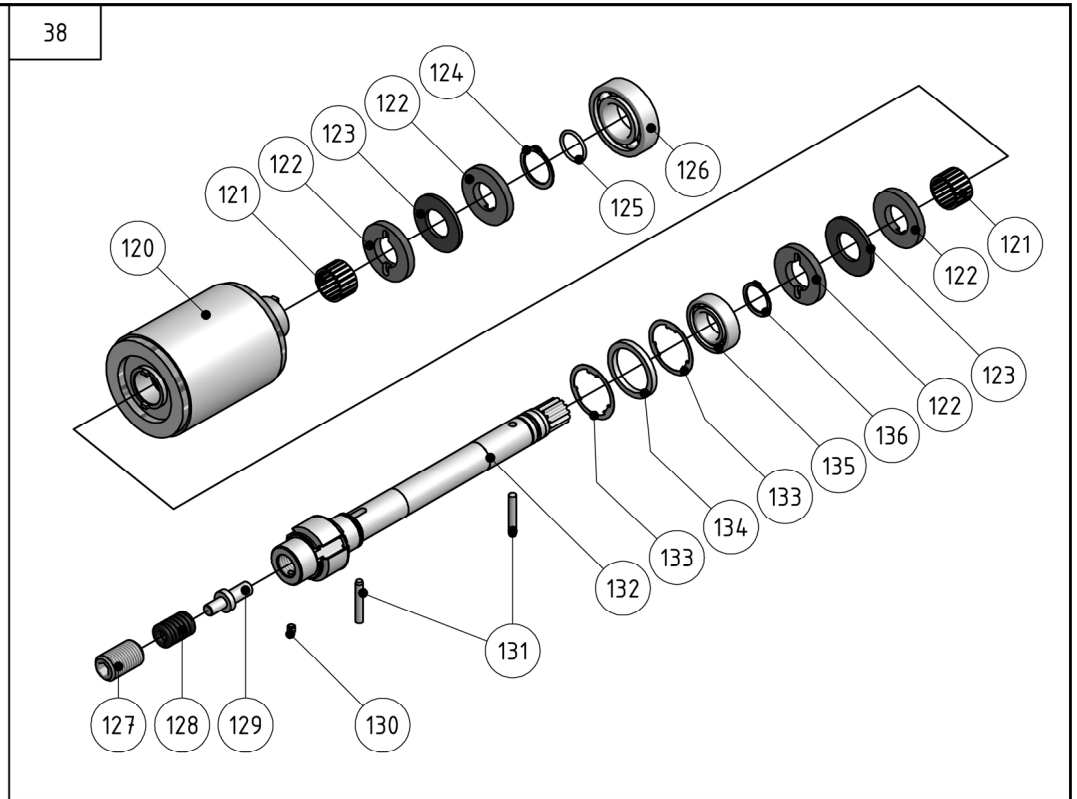
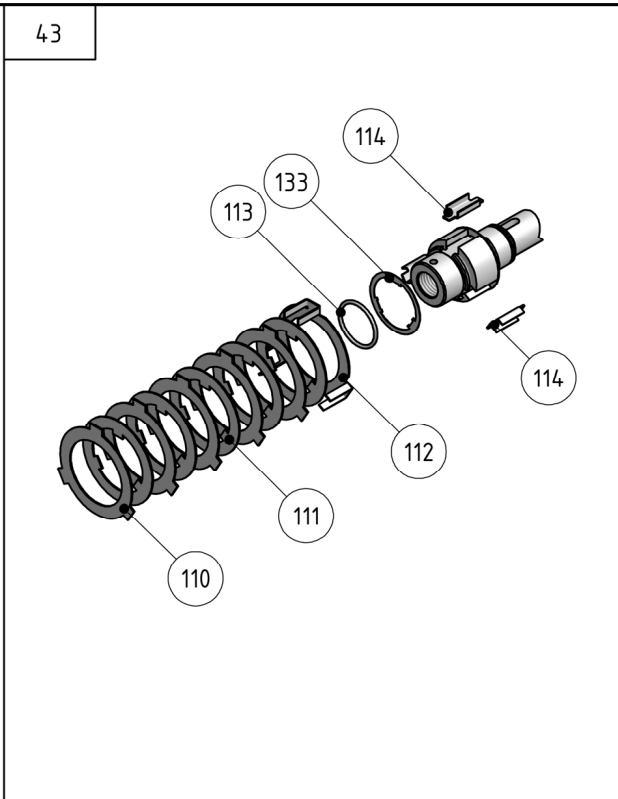
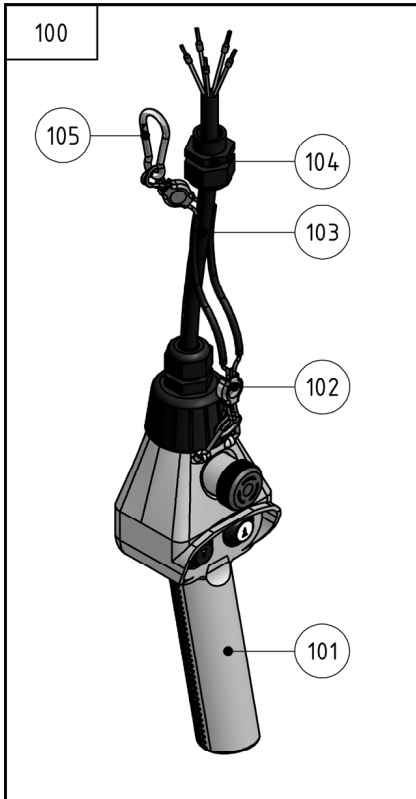

Elektrokettenzüge - Electric chain hoists - Palans électriques à chaîne

Schützensteuerung
 Contactor control
 Commande par contacteurs

1 Geschwindigkeit mit Not-Aus
 1 speed with emergency stop
 1 vitesse avec marche-arrêt

3 Ph 9400.9500.3

2 Geschwindigkeiten mit Not-Aus
 2 speeds with emergency stop
 2 vitesses avec marche-arrêt

3 Ph 9400.9501.3

F	Steuersicherung	Control fuse	Fusible de commande
K	Schütz	Contacteur	Contacteur
L	Zuleitung	Power supply	Alimentation électrique
N	Nullleiter	Neutral	Neutre
NA	Not-Aus	Emergency stop	Marche-arrêt
PE	Erdung	Earth	Mise à la terre
S	Schalter	Switch	Interrupteur
T	Transformator	Transformator	Transformateur
U, V, W	Motor	Motor	Moteur
X	Klemmenleiste	Terminal strip	Barrette de raccordement
Y	Bremse	Brake	Frein

9400.9500.3

3 Ph

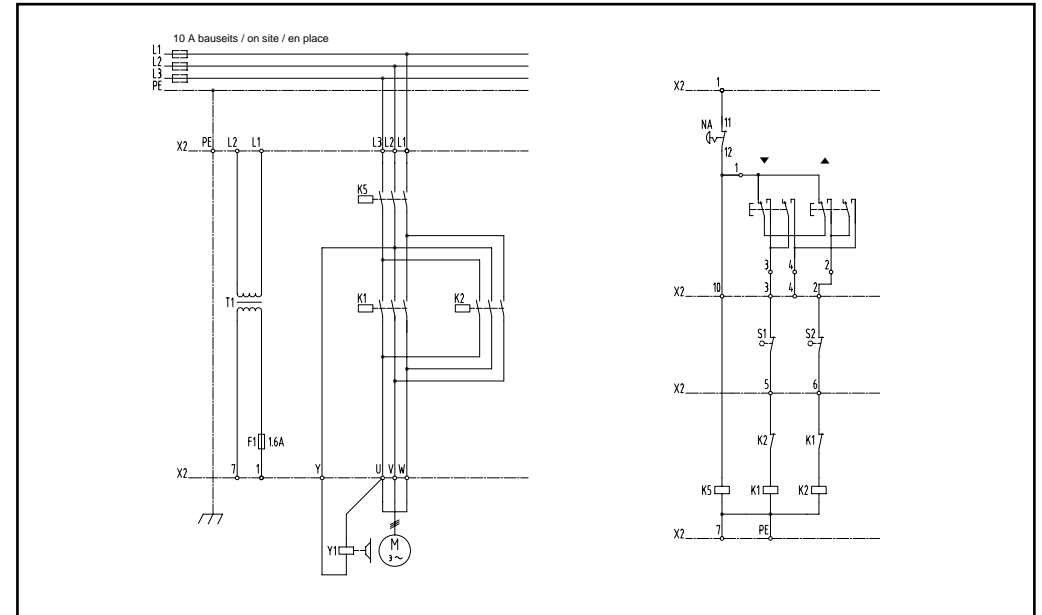

9400.9501.3

3 Ph

