



swiss lifting solutions

ERSATZTEILE | STROMLAUFPLÄNE GPS 1000 FU

Spare parts | Pièces de rechange | Onderdelen | Reservedele | Varaosat |
Pezzi di ricambio | Reservedelen | Peças | Reservdelar | Piezas de recambio

Circuit diagrams | Schéma de connexions | Stroomschema | Kredslobsdiagrammer |
Kytentäkaavio | Aansluitschema | Schema elettrico | Koplingskjema |
Esquema electrico | Elschema | Esquema eléctrico



since
1957

www.gis-ag.ch



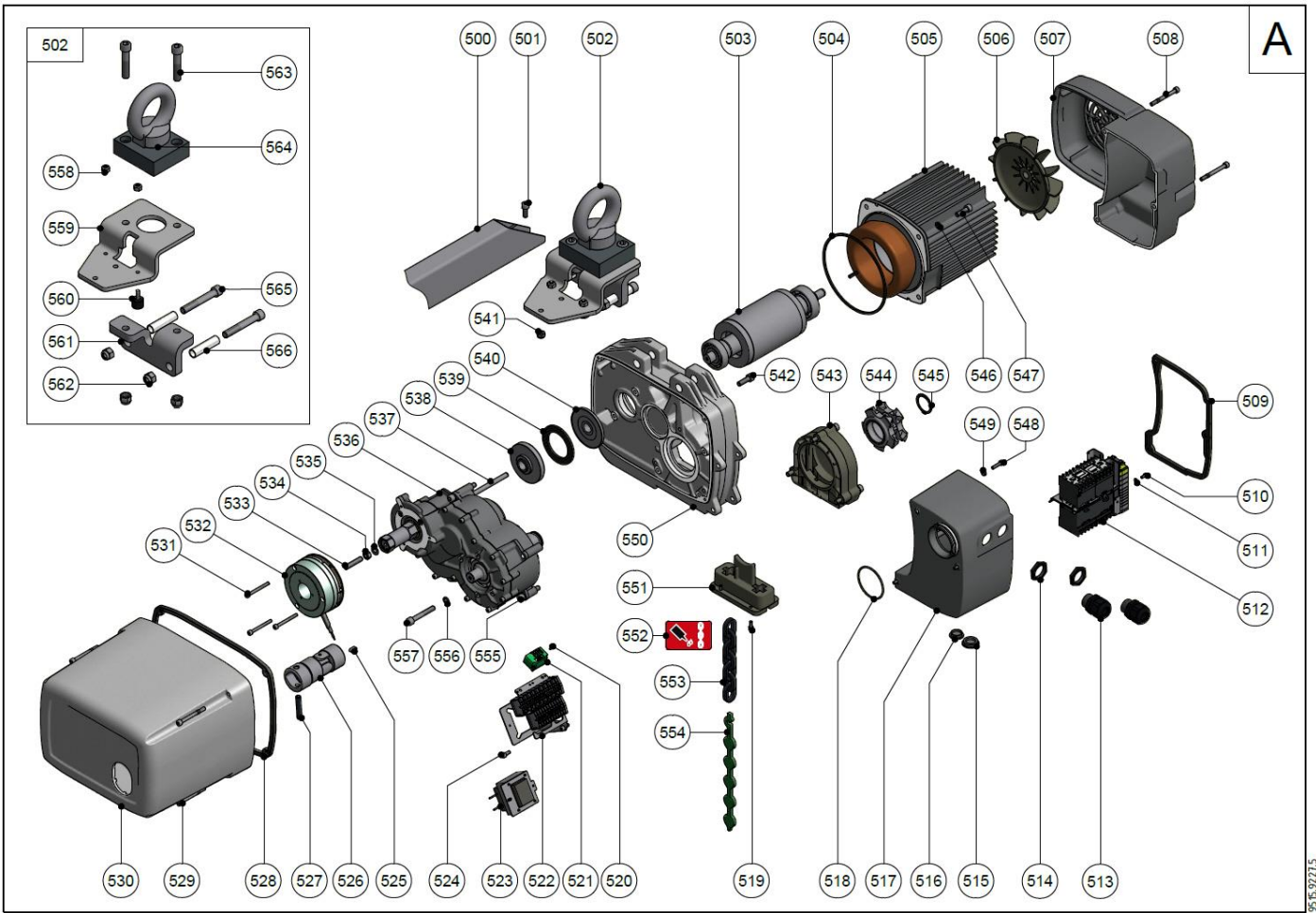

95.15.9272.5

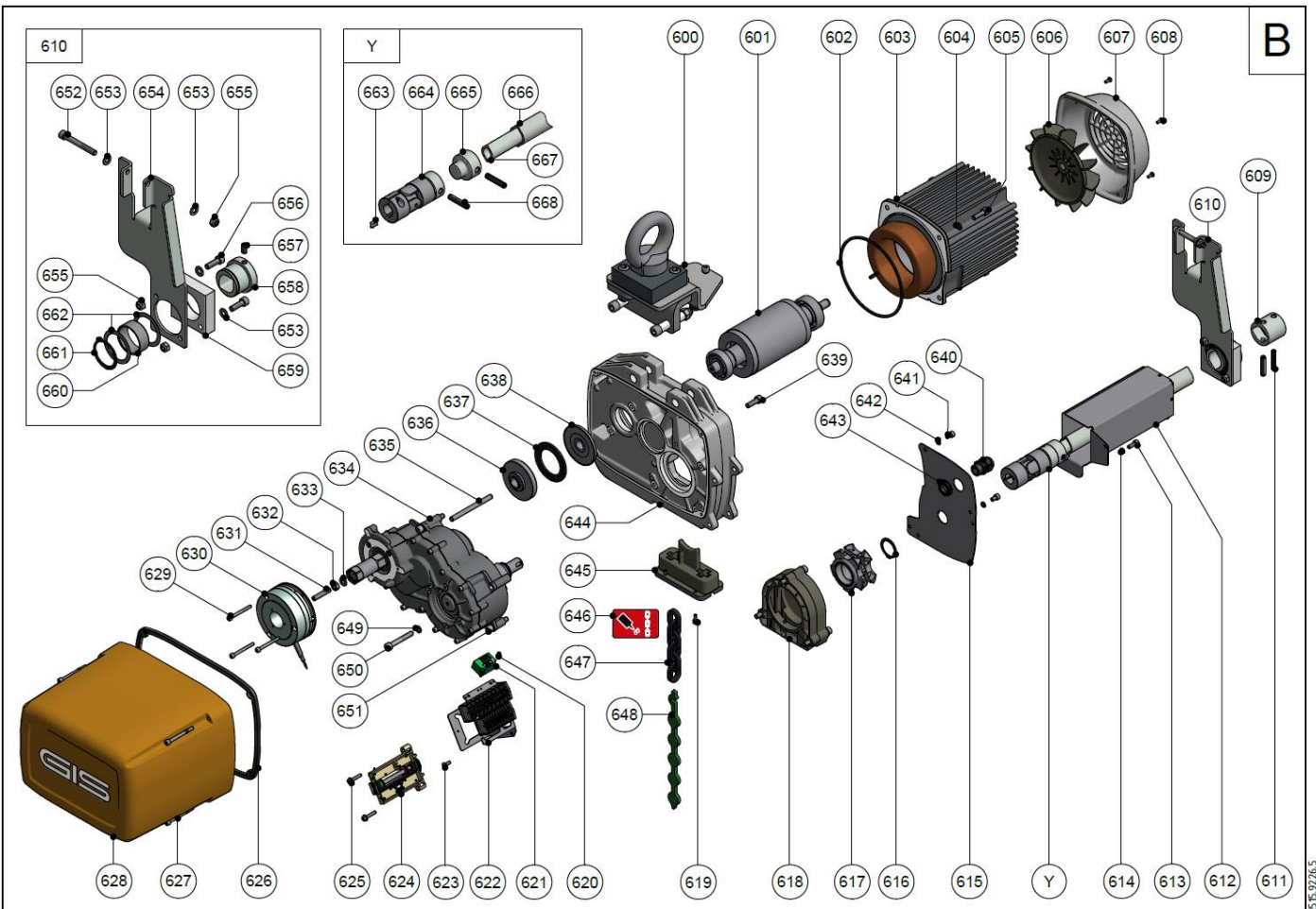

95.15.9276.5

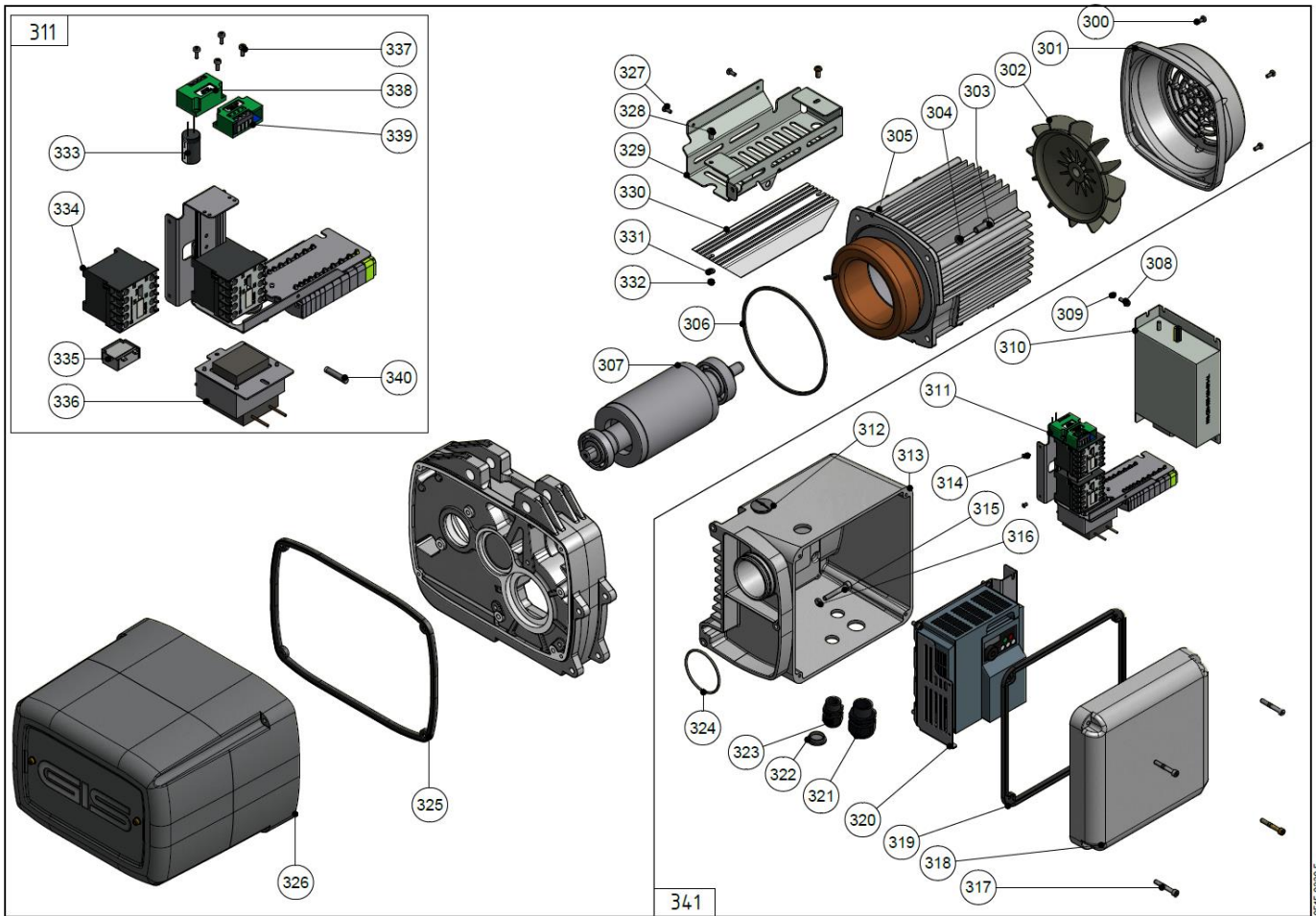

9515.9729.5

		GPS 1000 FU
300	M4 x 10	9030.8048
301	184 x 184 x 61.5	9515.3004.2
302	Ø166/Ø14 x 35	9515.3075.3
303	M8 x 20	9030.0286
304	M8	9031.3904
305	4p 3x230/400V 50Hz - NL	9517.0150.3
	2p 3x230/400V 50Hz - N	9517.0250.3
306	Ø156/Ø149 x 2.5	9515.3054.4
307	1t L=90-NL	9515.3028.3
	2t L=120-N	9515.3027.3
308	M4 x 12	9030.0024
309	M4	0031.0035
310	FR-D740	9056.5008
311	FU 1-t 400/24V DC	9517.1020.2
312	M25 x 1.5	9055.3513
313	264 x 219 x 152	9515.3012.2
314	3 x 7	9031.7300
315	M6 x 40/24	9030.0279
316	M6	9040.2508
317	M5 x 35/22 N	9030.0331
318	224 x 219 x 46.5	9515.3015.3
319	226 x 221 x 6	9515.3101.4

		GPS 1000 FU
320	FR-E740-095SC-EC	9515.3161.3
321	M25 x 1.5	9055.3103
322	M20 x 1.5	9055.3512
323	M16 x 1.5	9055.3102
324	Ø59 x 2.5 NBR 70	9035.0034
325	305 x 212 x 7	9515.3034.3
326	303 x 210 x 251	9515.3167.3
327	M4 x 10	9030.8048
328	M5 x 12	0030.3468
329	224.5 x 87.5 x 116	9515.3165.3
330	215 x 33 x 61	9405.3270.4
331	5.3/10 x 1	0031.0576
332	M5	0031.0036
333	1000µF Ø16 x 25	9059.0027
334	24V DC	9056.0075
335	RC-K1 24	9056.1009
336	400/17V	9056.4747.4
337	M3 x 8	9030.8030
338	PMEA 500	9050.4023
339	PMB 400	9050.4024
340	1.6A, UL	9052.0012
341	252 x 238 x 200	9515.2063.2

Frequenzsteuerung Inverter controlled		2 Geschwindigkeiten mit Not-Aus 2 speeds with emergency stop	3 Ph	9515.9561.2
F	Steuersicherung	Control fuse		
K	Schütz	Contactorr		
L	Zuleitung	Power supply		
N	Nullleiter	Neutral		
NA	Not-Aus	Emergency stop		
PE	Erdung	Earth		
S	Schalter	Switch		
T	Transformator	Transformer		
U, V, W	Motor	Motor		
X	Klemmenleiste	Terminal strip		
Y	Bremse	Brake		

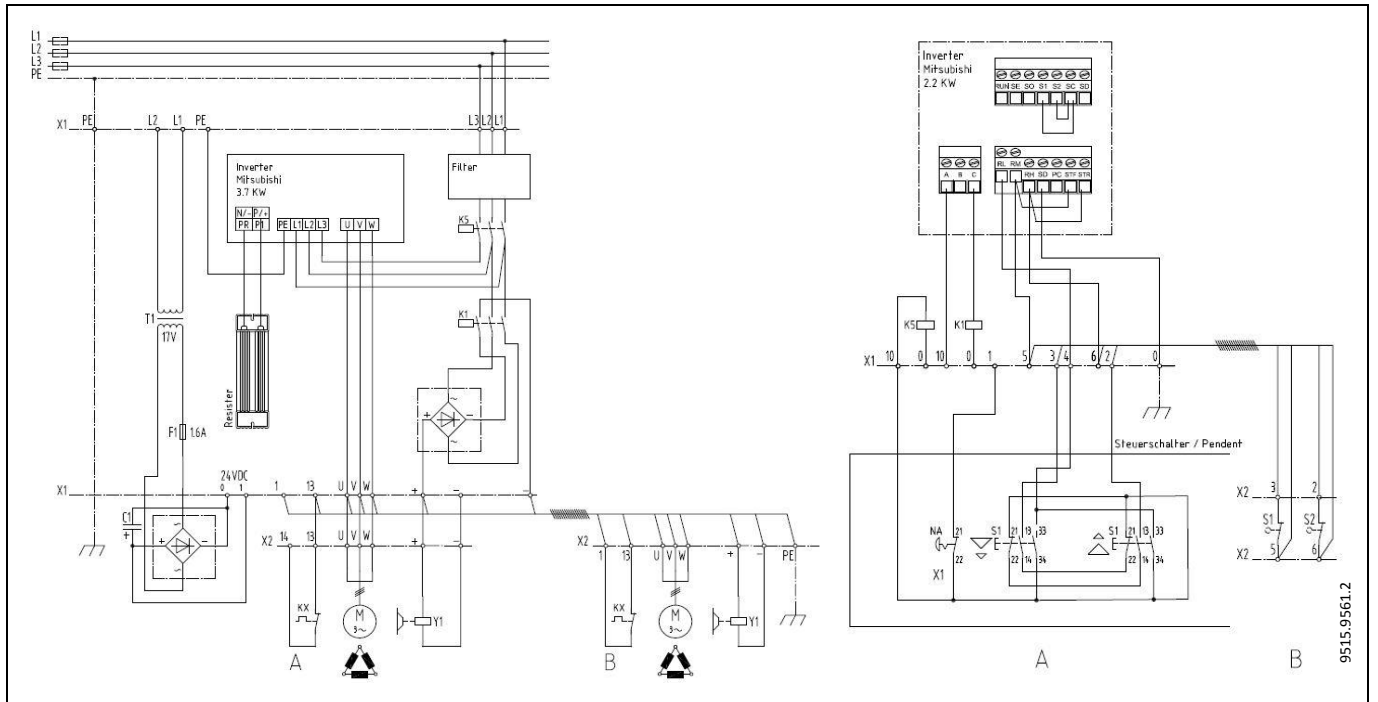

Parameter Frequenzumformer / Parameter Inverter				
Parameter	Bedeutung / Meaning	Einstellbereich Setting Range	Einstellung GIS / Setting GIS	
			-NL (4-pol Motor)	-N (2-pol Motor)
0	Drehmomentanhebung (manuell) / Torque boost	0-15%	0	0
1	Maximale Ausgangsfrequenz / Maximum frequency	0-120Hz	90	90
3	V/f-kennlinie (Basisfrequenz) / Base frequency	0-120 Hz	90	90
4	1. Drehzahl-/Geschwindigkeitsvorwahl-RH / Multi-speed setting (high speed)	0-120Hz	15 auf langsam / 15 up slow	15 auf langsam / 15 up slow
5	2. Drehzahl-/Geschwindigkeitsvorwahl-RM / Multi-speed setting (middle speed)	0-120Hz	15 ab langsam / 15 down slow	15 ab langsam / 15 down slow
6	3. Drehzahl-/Geschwindigkeitsvorwahl-RL / Multi-speed setting (low speed)	0-120Hz	87 schnell / 87 fast	60 schnell / 60 fast
7	Beschleunigungszeit Rampe auf / Acceleration time	0-999s	2	2
8	Bremszeit Rampe ab / Deceleration time	0-999s	0,7	0,7
9	Stromeinstellung für elektr. Motorschutz / Electronic thermal O/L relay	0-500A	50	50
10	DC-Bremung (Startfrequenz) / DC injection brake operation frequency	0-120Hz	0	0
11	DC-Bremung (Zeit) / DC injection brake operation time	0-10s	0	0
12	DC-Bremung (Spannung) / DC injection brake operation voltage	0-30%	0	0
18	Schnelldrehzahl Maximalfrequenz / High speed maximum frequency	120-400Hz	90	90
20	Bezugsfrequenz für Beschleunigungs-/Bremszeit Acceleration/deceleration reference frequency	1-120Hz	87	87
42	Frequenzüberwachung bei Rechtslauf / Output frequency detection	0-400Hz	3	3
43	Frequenzüberwachung bei Linkslauf / Output frequency detection for reverse rotation	0-400Hz	5	5
56	Bezugsgröße für externe Stromanzeige / Current monitoring reference	0-50A	12	12
72	PWM-Funktion / PWM frequency selection	1-15 0: 0.7kHz 15: 14.5kHz	8	8
77	Parameterschutz / Parameter write selection	0-15%	2	2
79	Betriebswahl / Operation mode selection	0-15%	2	2
156	Anwahl der Strombegrenzung / Stall prevention operation selection	0-15%	14	14
190	Funktionszuweisung RUN Klemme / RUN terminal function selection	0-15%	4	4
192	Funktionszuweisung ABC Klemme / ABC terminal function selection	0-15%	4	4
245	Motorschlupf / Rated slip	0-15%	6	6
246	Ansprechzeit Schlupfkompensation / Slip compensation time constant	0-15%	0.1	0.1