

## ERSATZTEILE | STROMLAUFPLÄNE GP 250/500

Spare parts | Pièces de rechange | Onderdelen | Reservedele | Varaosat |  
Pezzi di ricambio | Reservedelen | Peças | Reservdelar | Piezas de recambio

Circuit diagrams | Schéma de connexions | Stroomschema | Kredslobsdiagrammer |  
Kytkäntäkaavio | Aansluitschema | Schema elettrico | Koplingskjema |  
Esquema electrico | Elschema | Esquema eléctrico

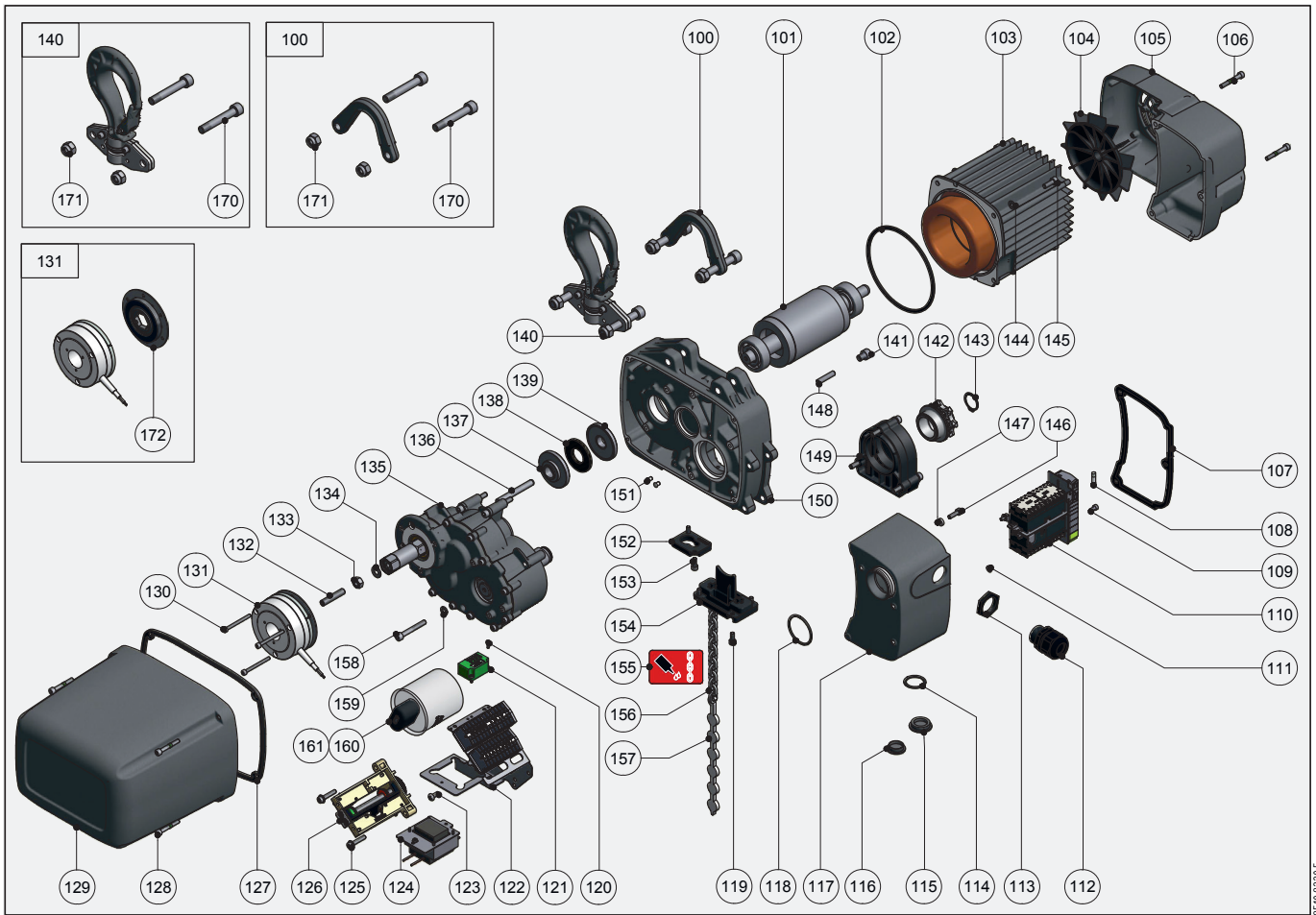



9510.9220.5

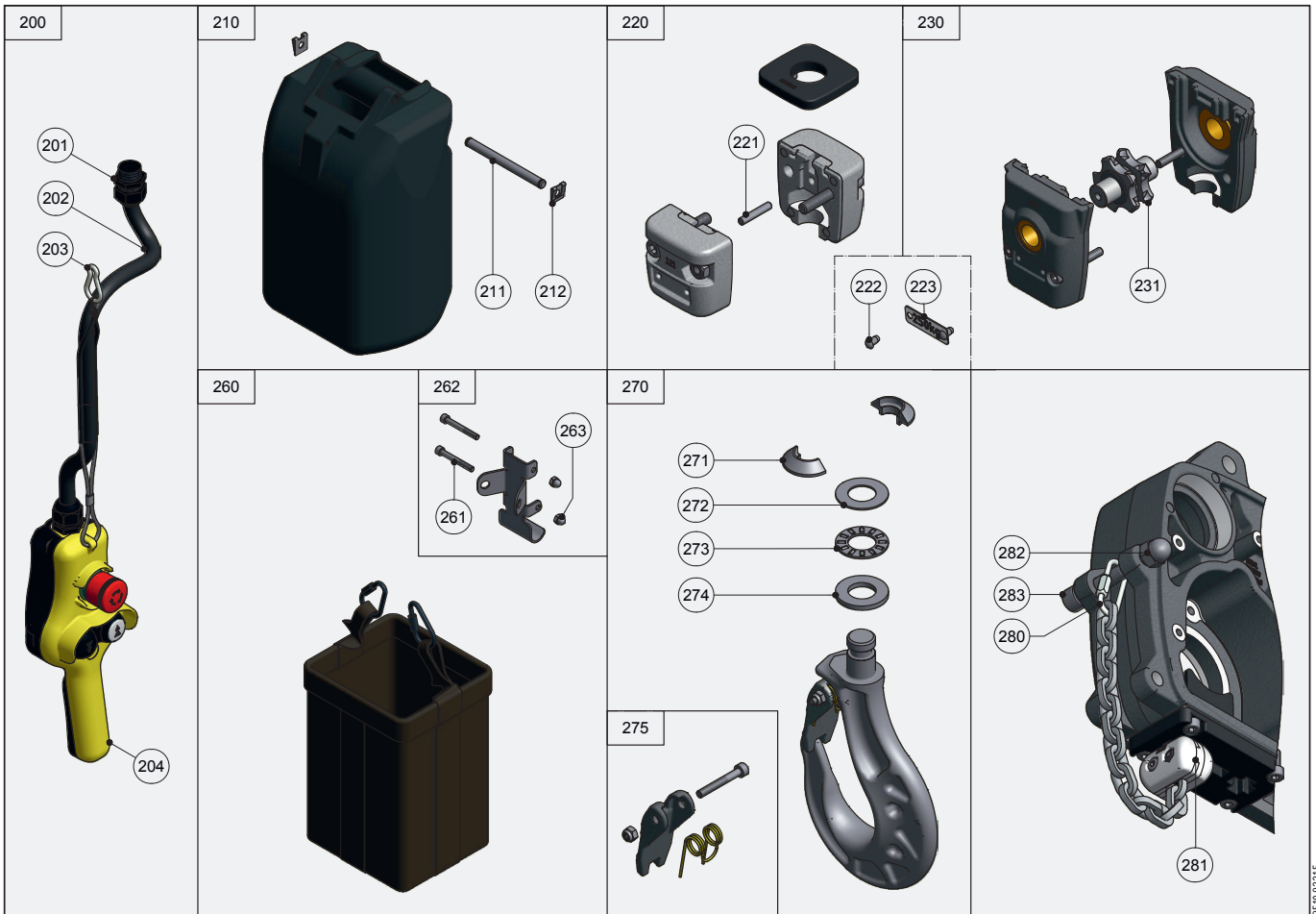

9510.9271.5

		GP 250	GP 500
100*	84 x 59	9510.3077.3	9510.3077.3
101	1t / 2t, L=90, -N/-NF	9510.3027.3	9510.3027.3
102	ø125 / ø117 x 2.5	9510.3054.4	9510.3054.4
103	2/8p, 3 x 400V 50Hz	9512.0350.3	9512.0350.3
	2/8p, 3 x 230V 50Hz	9512.0351.3	9512.0351.3
	2/8p, 3 x 460V 60Hz	9512.0350.3	9512.0350.3
	2p, 3 x 230/400V 50Hz, 3 x 460V 60Hz	9512.0250.3	9512.0250.3
	4p, 1 x 115/230V 50Hz	9512.0158.3	9512.0158.3
104	ø134 / ø13.5 x 35	9510.3062.3	9510.3062.3
105	165 x 88 x 232	9510.3011.1	9510.3011.1
106	M5 x 35/22 N	9030.0331	9030.0331
107*	110 x 166 x 5	9510.3033.3	9510.3033.3
108	0.4A UL	9052.0013	9052.0013
109	M4 x 8	9030.0325	9030.0325
110	2t+NA, 42V	9512.1100.2	9512.1100.2
	1t+NA, 42V	9512.1000.2	9512.1000.2
	1t+NA, 115/42V 1Ph	9512.1053.2	9512.1053.2
	1t+NA, 230/42V 1Ph	9512.1052.2	9512.1052.2
111	ø4.3 / ø8 x 0.8	9031.3706	9031.3706
112	M25 x 1.5	9055.3103	9055.3103
113	M25	9055.4013	9055.4013
114	ø29.5 / ø23.2 x 1	9040.2511	9040.2511
115	M25 x 1.5	9055.3513	9055.3513
116	M20 x 1.5	9055.3512	9055.3512
117	102 x 165 x 102	9510.3006.2	9510.3006.2
118	ø38.7 x 2.65 NBR 70	9035.0033	9035.0033
119	M5 x 12 T	9030.0003	9030.0003
120	M3 x 8	9030.8030	9030.8030
121	PMEA 500	9050.4023	9050.4023
122	1t, 2t, max. 480V	9512.1200.3	9512.1200.3
	DC	9512.1201.3	9512.1201.3
	1Ph	9512.1203.3	9512.1203.3
123	M5 x 10	9030.0027	9030.0027
124	400/42V 50/60Hz	9056.4601.4	9056.4601.4
	115/230/42V 50/60Hz	9056.4644.4	9056.4644.4
	230/460/42V 50/60Hz	9056.4641.4	9056.4641.4
125	M5 x 25	9030.0022	9030.0022
126	103 x 84 x 41	9500.3069.3	9500.3069.3
127*	230 x 162 x 5	9510.3034.3	9510.3034.3
128	M5 x 35/22 N	9030.0331	9030.0331
129	228 x 160 x 208	9510.3005.3	9510.3005.3
130	M4 x 45	0030.9287	0030.9287
131	3Nm, 100-125VAC 50/60Hz	9050.4082	
	6Nm, 100-125VAC 50/60Hz		9050.4055
	3Nm, 200-240VAC 50/60Hz	9050.4083	
	6Nm, 200-240VAC 50/60Hz		9050.4056
	3Nm, 360-420VAC 50/60Hz	9050.4084	
	6Nm, 360-420VAC 50/60Hz		9050.4057
	3Nm, 440-480VAC 50/60Hz	9050.4085	
	6Nm, 440-480VAC 50/60Hz		9050.4058
132	M8 x 40	9030.2018	9030.2018
133	M8	0031.0008	0031.0008
134	ø8.4 / ø16 x 1.6	0031.0578	0031.0578
135	195 x 148 x 201 N	9510.3020.2	9510.3020.2
	195 x 148 x 201 S	9510.3022.2	9510.3022.2
136	ø8 x 65	9031.5862	9031.5862
137*	ø45 x 13.2	9510.3059.4	9510.3059.4
138*	ø40 / ø26.5 x 4	9510.3057.4	9510.3057.4
139*	ø45 x 10.5	9510.3058.4	9510.3058.4
140*	171 x 115 x 34.6	9510.3078.3	9510.3078.3
141	M5 x 12	9030.0261	
	M8 x 10		9030.0332
142*	ø52.2 x 35.5	9510.3030.2	
	ø54 x 35.5		9511.3030.2
143	DIN 471, 22 x 1.2	9031.2013	9031.2013
144	M6	9031.3903	9031.3903
145	M6 x 16	9030.0275	9030.0275
146	M5 x 16	9030.0262	9030.0262
147	ø9.8 / ø5.1 x 3	9031.3705	9031.3705
148	ø4 x 22	9500.3134.4	
	ø6 x 30		9511.3066.4
149*	66 x 31 x 88	9510.3061.4	9511.3061.4
150	187 x 55 x 250	9510.3000.1	9510.3000.1
151	ø5.5/3.5 x 6	9040.0718	9040.0718
152	41.5 x 34 x 8.3	9510.3013.4	9510.3013.4
153	M5 x 12 T	9030.0003	9030.0003
154*	80 x 55 x 45	9510.3008.3	
	80 x 53 x 45		9511.3008.3
155	0.25 l	9041.0007	9041.0007
156*	3.75 x 10.75	9039.0028	
	5.25 x 15		9039.0029
157	140 x 12 x 3 (3.75)	9041.6034	
	193 x 17 x 5 (5.25)		9041.6035
158	M6 x 45/24	9030.0280	9030.0280
159	M6	9031.3903	9031.3903
160	110uF, 1Ph 230V 50Hz	9059.0024	9059.0024
	200uF, 1Ph 115V 50Hz	9059.0025	9059.0025
	275uF, 1Ph 115V 50Hz	9059.0020	9059.0020
161	4.5 x 360	0055.0818	0055.0818
170	M10 spez.	9400.3049.4	9400.3049.4
171	M10	9031.1278	9031.1278
172*	ø84 x 9	9400.3156.4	9400.3156.4

		GP 250	GP 500
200*	2K NA 3 m	9290.1086.3	9290.1086.3
	2K NA 4 m	9290.1087.3	9290.1087.3
	2K NA 5 m	9290.1088.3	9290.1088.3
	2K NA 6 m	9290.1089.3	9290.1089.3
	2K NA 7 m	9290.2014.3	9290.2014.3
	2K NA 8 m	9290.1090.3	9290.1090.3
	2K NA 10 m	9290.1091.3	9290.1091.3
	2K NA 12 m	9290.1092.3	9290.1092.3
	2K NA 15 m	9290.1093.3	9290.1093.3
	2K NA 20 m	9290.1094.3	9290.1094.3
201*	M20 x 1.5	9055.3102	9055.3102
202*	5 x 0.75 mm2	9055.0110	9055.0110
203	ø5 x 50	9031.8004	9031.8004
204*	2K NA	9290.2000.3	9290.2000.3
210	250 x 120 x 155, 8 m/6 m KS	9510.3016.1	9510.3016.1
	370 x 120 x 155, 24 m/12 m KS	9510.3019.1	9510.3019.1
211	ø8 x 94	9510.3056.4	9510.3056.4
212	15 x 17 x 3.5	9031.2400	9031.2400
220*	48 x 48 x 53	9510.3018.3	
	48 x 48 x 58		9511.3109.3
221*	ø4 x 22	9500.3134.4	
	ø6.5 x 30		9511.3066.4
222	ø3 x 5	9031.6604	9031.6604
223	100 kg	9210.3717.4	
	125 kg	9210.3718.4	9210.3718.4
	160 kg	9210.3719.4	9210.3719.4
	200 kg	9210.3720.4	9210.3720.4
	250 kg	9210.3721.4	9210.3721.4
	320 kg	9210.3722.4	9210.3722.4
	400 kg	9210.3723.4	9210.3723.4
	500 kg	9211.3340.4	9211.3340.4
	630 kg	9211.3341.4	9211.3341.4
	800 kg		9211.3342.4
	1 t		9216.3041.4
	1.25 t		9511.3068.4
230	45 x 69 x 79	9510.3017.3	
	62 x 88 x 101		9511.3017.3
231	ø22 x 45	9510.3035.4	
	ø20 x 60		9511.3035.4
260	192 x 212 x 320, XS, 250/40, 500/20	9510.3084.3	9510.3084.3
	192 x 212 x 420, S, 250/60, 500/30	9510.3085.3	9510.3085.3
	192 x 212 x 590, M, 250/120, 500/60	9510.3086.3	9510.3086.3
	192 x 212 x 880, L, 500/100	9510.3088.3	9510.3088.3
	192 x 212 x 940, XL, 500/120	9510.3087.3	9510.3087.3
261	M8 x 65/28	9030.0313	9030.0313
262	145 x 83 x 73	9510.3103.3	9510.3103.3
263	M8	9031.1052	9031.1052
270*	154 x 97 x 27	9510.3075.4	
	157 x 97 x 27		9511.3075.4
271	13.5 x 27 x 9	9215.3134.4	
	14.5 x 29 x 11		9216.3134.4
272*	ø28 x ø15 x 1	9038.1754	
	ø30 x ø17 x 1		0038.3133
273*	DIN 5405-T2 AXK1528	9038.0258	
	DIN 5405-T2 AXK1730		9038.0250
274*	ø28 x ø15 x 2.75	9038.1753	
	ø30 x ø17 x 2.75		9038.1755
275*	54 x 23	9510.3079.4	9510.3079.4
280	ø3 x 40	9039.0410	9039.0410
281	36 x 22	9500.3013.3	
	44 x 32		9511.3013.3
282	M8	9031.1052	9031.1052
283	M8 x 60	9030.0293	9030.0293

Schützensteuerung Contactor control Commande par contacteurs	1 Geschwindigkeit mit Not-Aus 1 speed with emergency stop 1 vitesse avec marche-arrêt	9510.9500.4 / 3 Ph
	2 Geschwindigkeiten mit Not-Aus 2 speeds with emergency stop 2 vitesses avec marche-arrêt	9510.9501.4 / 3 Ph
	1 Geschwindigkeit mit Not-Aus 1 speed with emergency stop 1 vitesse avec marche-arrêt	9510.9524.3 / 1 Ph

F	Steuersicherung	Control fuse	Fusible de commande
K	Schütz	Contacteur	Contacteur
L	Zuleitung	Power supply	Alimentation électrique
N	Nullleiter	Neutral	Neutre
NA	Not-Aus	Emergency stop	Marche-arrêt
PE	Erdung	Earth	Mise à la terre
S	Schalter	Switch	Interrupteur
T	Transformator	Transformer	Transformateur
U, V, W	Motor	Motor	Moteur
X	Klemmenleiste	Terminal strip	Bornier de raccordement
Y	Bremse	Brake	Frein

9510.9500.4 / 3 Ph

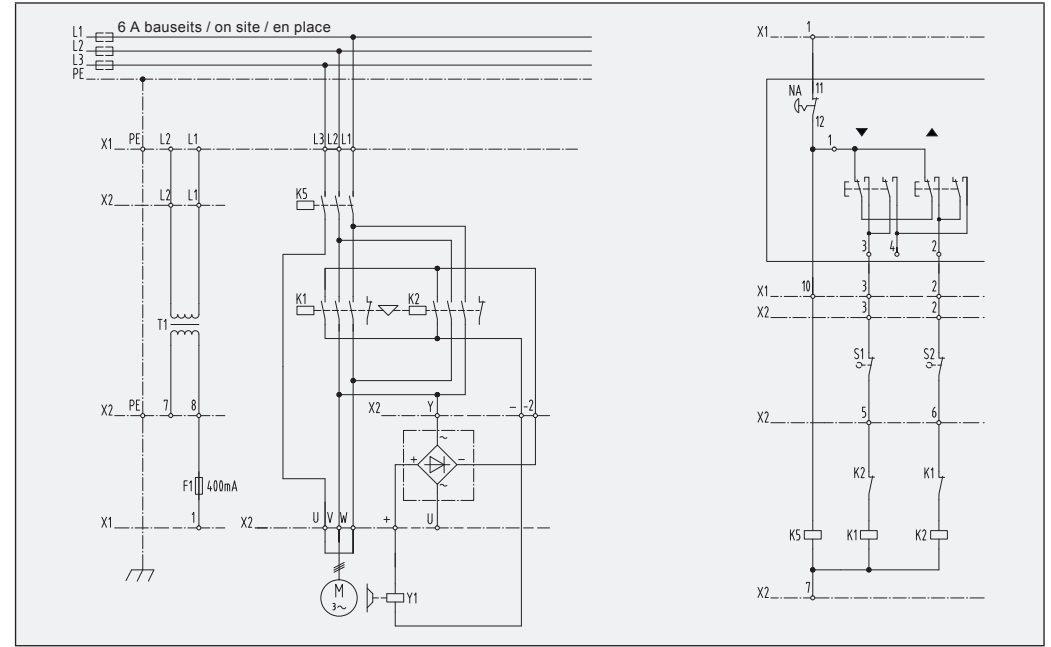

9510.9524.3 / 1 Ph

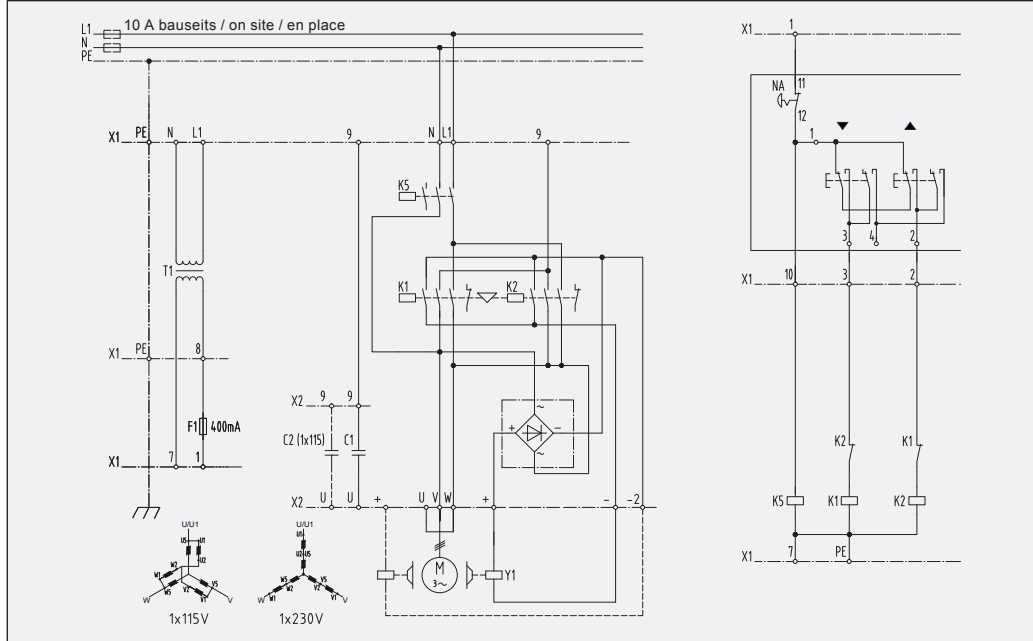

9510.9501.4 / 3 Ph

