

Option - Stützrollen (Min. Kurvenradius: 2200 mm)
 - Carrier rollers (Min. radius: 2200 mm)
 - Galet de roulement (Rayon min.: 2200 mm)

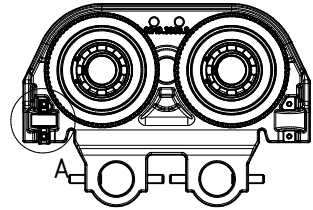

A

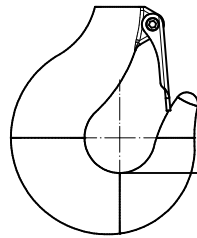
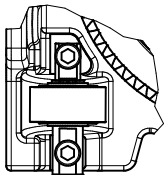

GP 1600/1 = 633
 GP 1600/2 = 701
 (GP 2500/1 = 673)
 (GP 2500/2 = 762)

Optionen Fahrwerk:

- Laufrollen für konische Träger
- Laufrollen: Kunststoff, Stahl
- Fahrwerk mit Stützrollen für Kurven
- Puffer am Fahrwerk
- Seitenschild KTL

Options trolley:

- Load wheels for conical beams
- Load wheels: plastic, steel
- Trolley with carrier rollers for curves
- Buffer on trolley
- KTL side plate

Options chariot:

- Galets de roulement pour poutres coniques
- Galets de roulement: plastique, acier
- Chariot avec galets de support pour déplacements en courbe
- Butoir au chariot
- Flasque KTL

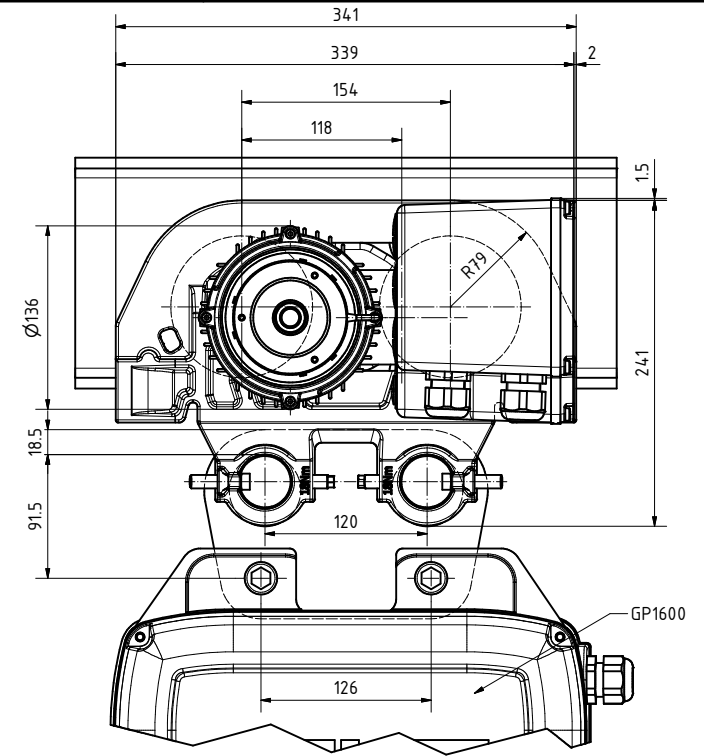

Optionen Antrieb:

- Temperaturüberwachung, Sonderspannung, Sondersteuersp.
- Fahrendschalter, Bremse IP65
- Spez. Getriebe fett, Lebensmitteltaugl. od. tieftemp.
- ATEX

Options drive unit:

- Temperature surveillance, special operating voltage, special control voltage
- Travel limit switch, brake IP65
- Special gear grease, food grade or low temperature
- ATEX

Versión motor:

- Surveillance de température, tension d'alimentation spéciale, tension de commande spéciale
- Interrupteur de fin de course, frein IP65
- Graisse d'engrenage spéciale, apte à aliments ou à basse température
- ATEX

Triebwerksgruppe Classification Groupe DIN EN 144 92/ISO	A3/M3	A4/M4	A5/M5	A6/M6	A6/M6	Fahrgeschw. Travelling speed	Fahrgeschw. Travelling speed	Leistung Motor power			Geeignet für Parallel Flansch-Träger For parallel flange girder only Seulement pour profilé avec ailes parallèles	Gewicht Weight Poids	63 kg	-Schutzart nach DIN 40050: -Isolationsklasse:	IP54 F	
Zyklen /Tag Cycles /day Cycles /jour	15	30	60	120	120	Vitesse de translation 50Hz	Vitesse de translation 60Hz	Puissance	3x400V 50Hz	3x230V 50Hz	Tragbolzen Spindle No. Axe No.	9249.3004.3	Min. Kurvenradius Min. radius Rayon min.	1'800 mm	-Protection DIN 40050: -Insulation class:	IP54 F
ED % Duty factor % Facteur de marche %	(25)	(30)	(40)	(50)	(50)	[m/min]	[m/min]	[kW] 18m	[A]	[A]	Einstellbare Flanschbreite b Adjustable flange width b Largeur d'aile b	[mm] [mm] [mm]	91-300	-Classe de protection DIN 40050: -Classe d'isolation:	IP54 F	
GMF5000/NF	5000	4000	3200	-	-	12/4	14.4/4.8	2x 0.15/0.045	2x 0.65/0.75	2x 1.0/1.2						
GMF5000/SF	5000	4000	3200	-	-	24/6	28.8/7.2	2x 0.3/0.075	2x 1.0/0.9	2x 1.8/1.6						
-	-	-	-	-	-	-	-	-	-	-						
-	-	-	-	-	-	-	-	-	-	-						

GMF 5000



swiss lifting solutions

Massstab Echelle	Gezeichnet Besenbart Modifié par Gepüft Contrôlé Fregabe hora Autorisé nom	T.Keller
1:2.8		

9249.9207.5

Index
B