



Lever hoist PLANETA – PREMIUM PRO-EX

The next development stage of the reliable PLH-PREMIUM lever hoist is the PREMIUM PRO. Thanks to a significant weight saving, handling is improved. Despite this, the frame has been strengthened compared to the previous generation. Proven quality also ensures longevity and its design makes it very robust.

Free-running mode

When the selection switch is moved to the middle point, the unladen chain can easily be pulled through the device freely to the required usage length. This makes tensioning the chain easier.

Load chain

The tempered, galvanised load chain according to DIN EN 818-7-T is supplied with the unit. The standard lifting height is 1.5 m; any length required for higher lifting is possible.

New chain end piece

The robust chain end piece provides additional safety because it cannot be pulled through the device with the chain.

Protected handle

The ergonomic rubber handle on the end of the lever protects the user against injury and is also screwed in place to prevent it slipping.

Technical advantages

Hand lever can be used in any position thanks to the ratchet; safety automatic mechanical brake; galvanised connecting parts; cast hook clip; large, non-slip and closed hand wheel; safety chain end piece.

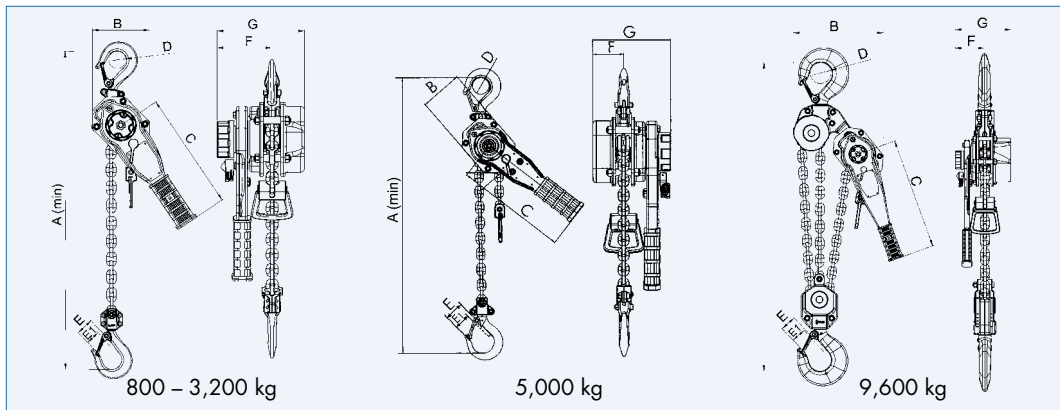

PREMIUM PRO-EX 1.6



PREMIUM PRO-EX 3.2

Even with 5,000 kg capacity only one chain fall!



TYPE	PREMIUM PRO-EX ...	0.8	1.6	3.2	5**	6.4	9.6
Capacity Basic/Medium	kg	800	1,600	3,200	5,000	6,400	9,600
Capacity High	kg	450	1,200	1,600	3,300	3,200	4,800
Standard lift	m	1.5	1.5	1.5	1.5	1.5	1.5
Min. headroom (A)	mm	320	360	431	655	500	635
Lever force	daN	22	24	33	37	36	38
Meters load chain movement with 1 round 360°	m	0.019	0.015	0.016	0.009	0.008	0.005
Number of chain falls		1	1	1	1	2	3
Chain size	mm	5.6 x 17	7.1 x 21	9 x 27*	13 x 36	9 x 27*	9 x 27*
B (Dimensions)	mm	115	137	169	180	238	300
C	mm	239	259	374	400	374	374
D	mm	35	42	48	60	60	70
E	mm	35	38	46	43	59	54
E1	mm	23	28.5	33	41	39	51
F	mm	91	67	98	104	98	98
G	mm	146	162	187	213	187	187
Weight with standard lift	kg	6.3	8.8	16.4	32.5	24.9	42.1
Weight for 1m additional lifting height	kg	0.7	1.1	1.8	3.7	3.6	5.4
Version Basic: PREMIUM PRO-EX ... with 1.5 m lift	Order No.	G10320	G10321	G10322	G10323	G10324	G10325
Version Medium: PREMIUM PRO-EX ... with 1.5 m lift	Order No.	G10326	G10327	G10328	G10329	G10330	G10331
Add. lifting height per m Basic / Medium	Order No.	G10086	G10087	G10249	G10287	G10254	G10256
Version High: PREMIUM PRO-EX ... with 1.5 m lift	Order No.	G10338	G10339	G10340	G10341	G10342	G10343
Add. lifting height per m High	Order No.	-	G10345	G10346	G10347	G10348	G10349

* Grade 100 ** chromated