



MANUAL CHAIN HOIST | PREMIUM PRO-II

Compact and light

The new PREMIUM PRO-II chain hoist is the systematic development of the established PREMIUM series and is manufactured using the latest technology. Compared to its predecessors, it is much lighter and provides better handling thanks to its compact design. Despite the weight saving, working stability has been improved thanks to the clever construction. The chromeplated housing for corrosion protection and overload protection as standard reinforce the high quality of the PLANETA-PREMIUM PRO product.

Load chain

Tempered and galvanised load chain "Made in Germany" according to DIN EN 818-7-T. Up to 3 t in a single strand. Higher lifting on request, any length can be delivered.

Galvanised or powder-coated on all sides

Dirt or rain have no effect on this device. All connection and housing parts are protected against corrosion.

Chain mounting

Thanks to the easily-accessible chain mounting, any user can insert a longer chain if required.

Options:

- Short model as a combination of chain hoist PREMIUM PRO and trolley
- Chain bag as an accessory
- Also available with GL (Germanischer Lloyd) certification!
- For shipyards, ships and the chemical industry.
- ATEX-Design

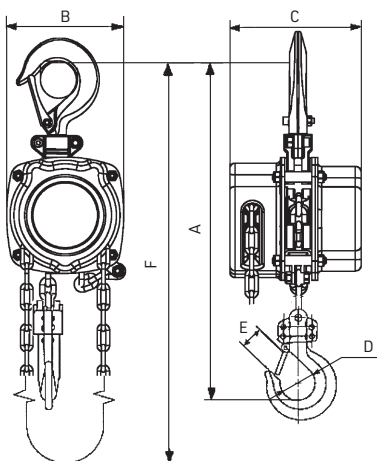

PREMIUM PRO-II 250 - 3,000 kg

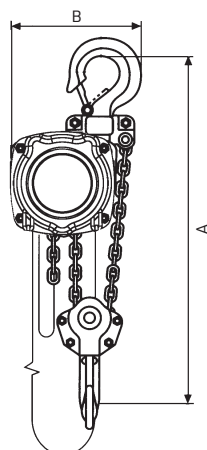

PREMIUM PRO-II 5,000 kg

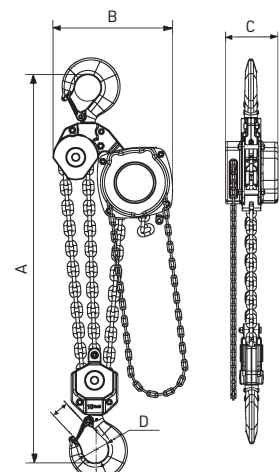

PREMIUM PRO-II 10,000 kg

Safety brake with two pawls hold the load in any position safely!
All parts corrosion protected!

Extra brake dust cover

Standard overload protection (over 500 kg)

Chain mounting for lower terminal link

Tempered and galvanized load chain acc. DIN EN 818-7-T

Option: Chain bag

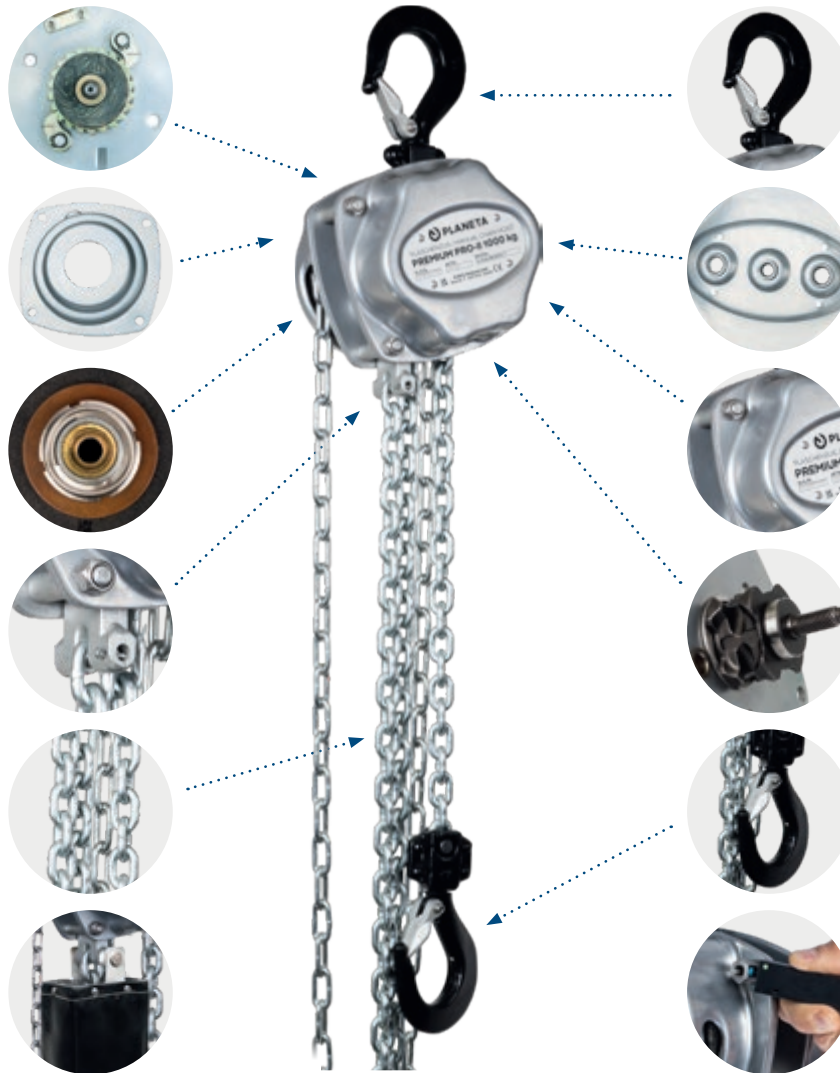

Swivelling top and bottom hook

3-fold bearing of the gearbox

Powder-coated (RAL 9022) housing for best corrosion protection

Ball bearing mounted sprocket shaft

New cast hook clips

Option:
With RFID chip for digital equipment testing.
More on page 08.

TYPE	PREMIUM PRO ...	0.25	0.5	1	1.5	2	3	5	10	15	20	30	40	
Capacity	kg	250	500	1,000	1,500	2,000	3,000	5,000	10,000	15,000	20,000	30,000	40,000	
Standard lift	m	3	3	3	3	3	3	3	3	3	3	3	3	
Min. headroom (A)	mm	285	316	367	409	428	504	637	735	1,036	1,031	1,149	1,557	
Hand chain force	daN	22	22.1	33.2	32.3	43	40.6	33.8	45.1	36	38	40	40	
Hand chain operation length	m	2.5	2.5	2.5	2.5	2.5	2.5	2.5	2.5	2.5	2.5	2.5	2.5	
Meters hand chain to pull to lift 1 m	m	14.8	29.5	39.4	60.8	60.8	96.7	193.3	290	290	386.7	580	773.3	
Number of chain falls		1	1	1	1	1	1	2	3	6	8	12	16	
Chain size	mm	4 × 12	5 × 15	6 × 18	8 × 24	8 × 24	10 × 30	10 × 30	10 × 30*	10 × 30	10 × 30	10 × 30	10 × 30	
B (Dimensions)	mm	102	122	152	176	176	216	259	344	441	432	532	961	
C	mm	112	117	144	156	156	167	167	167	221	222	220	282	
D	mm	35	35	44	48	50	59	68	91	97	106	150	216	
E	mm	23	23	30	31	34	40	47	61	65	73	92	148	
F	m	2.5	2.5	2.5	2.5	2.5	2.5	2.5	2.5	2.5	2.5	2.5	2.5	
Weight with standard lift	kg	5.9	7.6	11.5	17.2	17.2	27	40.5	61.9	137.9	202.9	268.9	440	
Weight for 1 m additional lifting height**	kg	1.2	1.4	1.7	2.3	2.3	3.1	5.3	7.5	14.9	19.3	28.1	36.9	
PREMIUM PRO-II ... with 3 m lift	Order No.	G10310	G10311	G10312	G10313	G10314	G10315	G10316	G10317	G10308	G10318	G10319	G10309	
PREMIUM PRO-II ... with 6 m lift	Order No.	G11310-6	G11311-6	G11312-6	G11313-6	G11314-6	G11315-6	G11316-6	G11317-6	G11318-6	G11319-6	G11320-6	G11321-6	
PREMIUM PRO-II ... with 10 m lift	Order No.	G11310-10	G11311-10	G11312-10	G11313-10	G11314-10	G11315-10	G11316-10	G11317-10	G11318-10	G11319-10	G11320-10	G11321-10	
Additional 1 m lift	Order No.	G10270	G10271	G10242	G10243	G10243	G10272	G10246	G10247	G10273	G10248	G10058	G10274	
RFID-Chip incl. mounting	Order No.	G10600	G10600	G10600	G10600	G10600	G10600	G10600	G10600	G10600	G10600	G10600	G10600	
Chain bag Size 1	max. lift in m	26	16	11	6	6	4	2	o. A.		o. A.		o. A.	
	Order No.	G10500	G10501	G10502	G10503	G10504	G10505	G10506	G10507	on request		G10508	G10509	on request
Chain bag Size 2	max. lift in m	32	19	14	8	8	5	2.5	o. A.		o. A.		o. A.	
	Order No.	G10510	G10511	G10512	G10513	G10514	G10515	G10516	G10517	on request		G10518	G10519	on request
Chain bag Size 3	max. lift in m	38	22	17	10	10	6	3	o. A.		o. A.		o. A.	
	Order No.	G10520	G10521	G10522	G10523	G10524	G10525	G10526	G10527	on request		G10528	G10529	on request

* Grade 100 **1 m operating length and 1 m lift